

SEWER CROSSING OVER

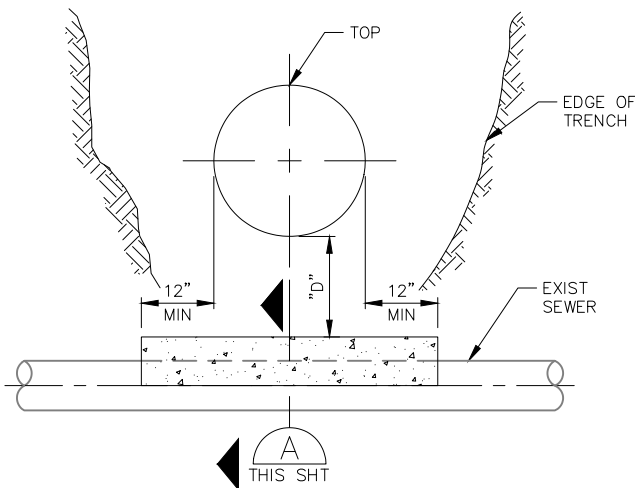

SEWER CROSSING UNDER
WITH "D" LESS THAN 18"

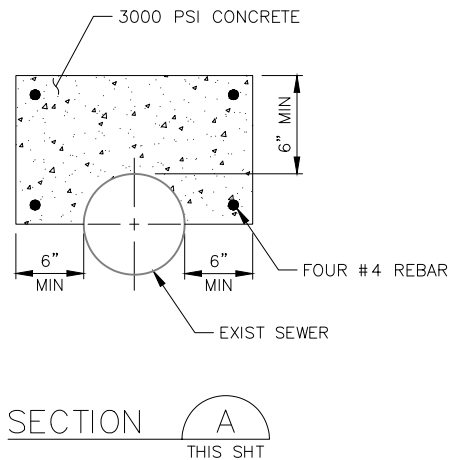

SECTION A
THIS SHT

NOTES:

1. ANY EXISTING SEWER DAMAGED DURING INSTALLATION MUST BE REPLACED WITH PVC PIPE.
2. APPROVED FLEX COUPLING SHALL BE USED: FERNCO 5000 SERIES REPAIR COUPLING, MISSION FLEX-SEAL ADJUSTABLE REPAIR COUPLING, ONSET SHEAR GUARD.



34501 E. Quincy Ave., Bldg. 34
WATKINS, COLORADO 80137
Tel: (303) 292-3456
www.purecyclewater.com

**STORM & SANITARY SEWER
CROSSING**

Date: MAY 2018

SHEET No. 15

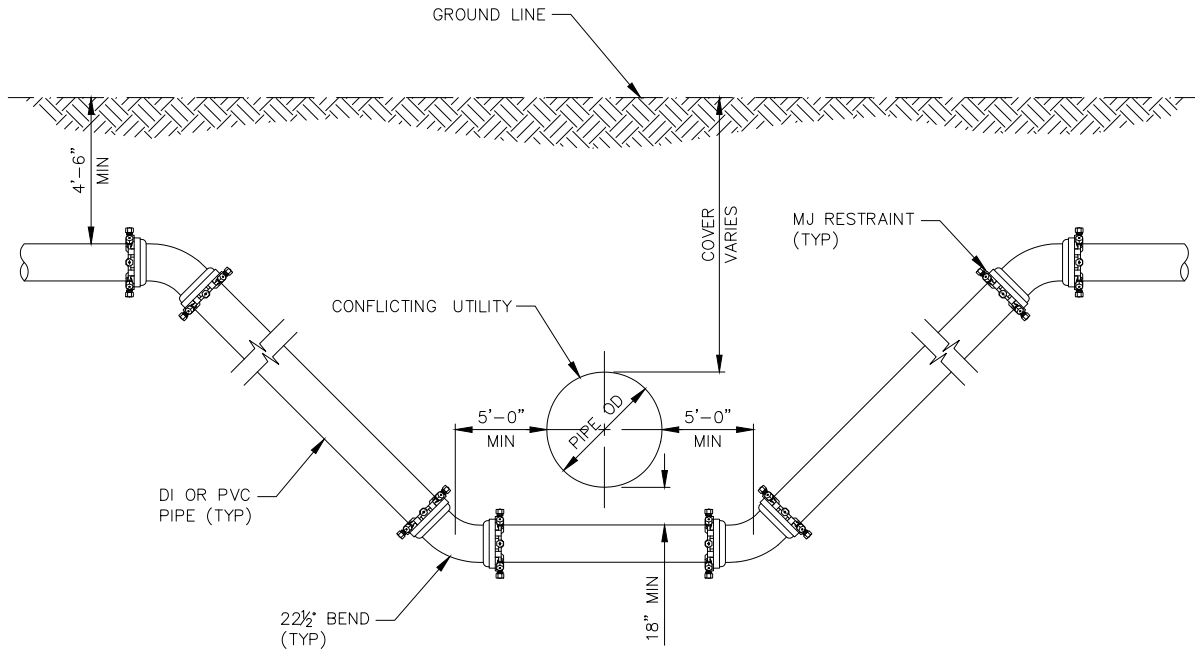

WATER CROSSING UNDER

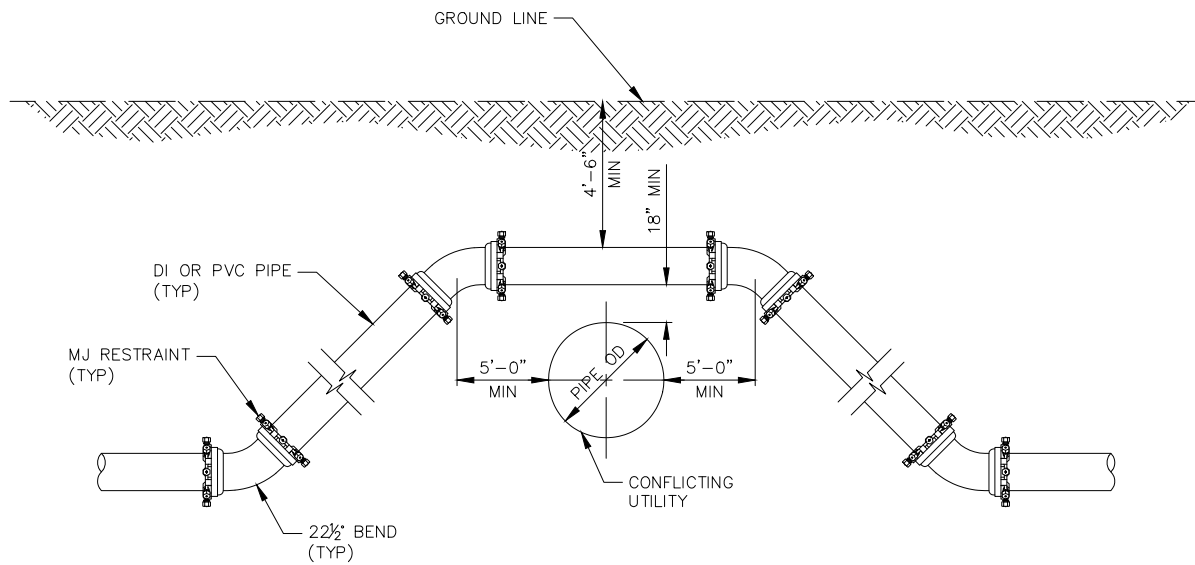

WATER CROSSING OVER

NOTES:

1. MAINTAIN CONTINUOUS RESTRAINT BETWEEN ALL BENDS WITH MJ RESTRAINT GLANDS, BELL RESTRAINTS, OR OTHER APPROVED METHODS.



34501 E. Quincy Ave., Bldg. 34
 WATKINS, COLORADO 80137
 Tel: (303) 292-3456
 www.purecyclewater.com

WATER CROSSING CONFLICTING UTILITY

Date: MAY 2018

SHEET No. 16

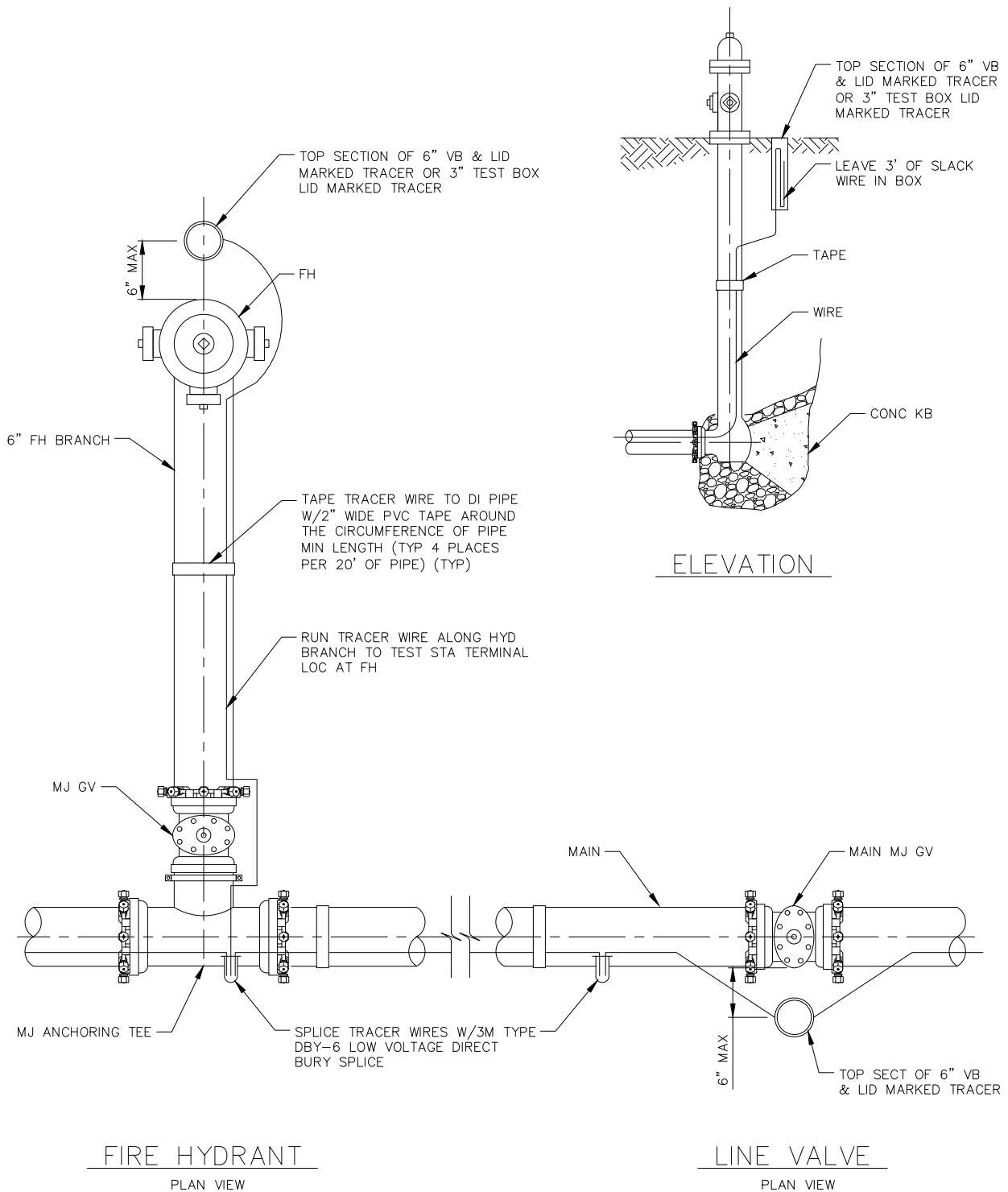

NOTE:

1. CONTRACTOR TO TEST TRACER WIRE FOR CONTINUITY AFTER INSTALLATION AND PROVIDE RANGEVIEW A REPORT WITH THE TEST RESULTS.



34501 E. Quincy Ave., Bldg. 34
 WATKINS, COLORADO 80137
 Tel: (303) 292-3456
 www.purecyclewater.com

TRACER WIRE

Date: MARCH 2021

SHEET No. 37

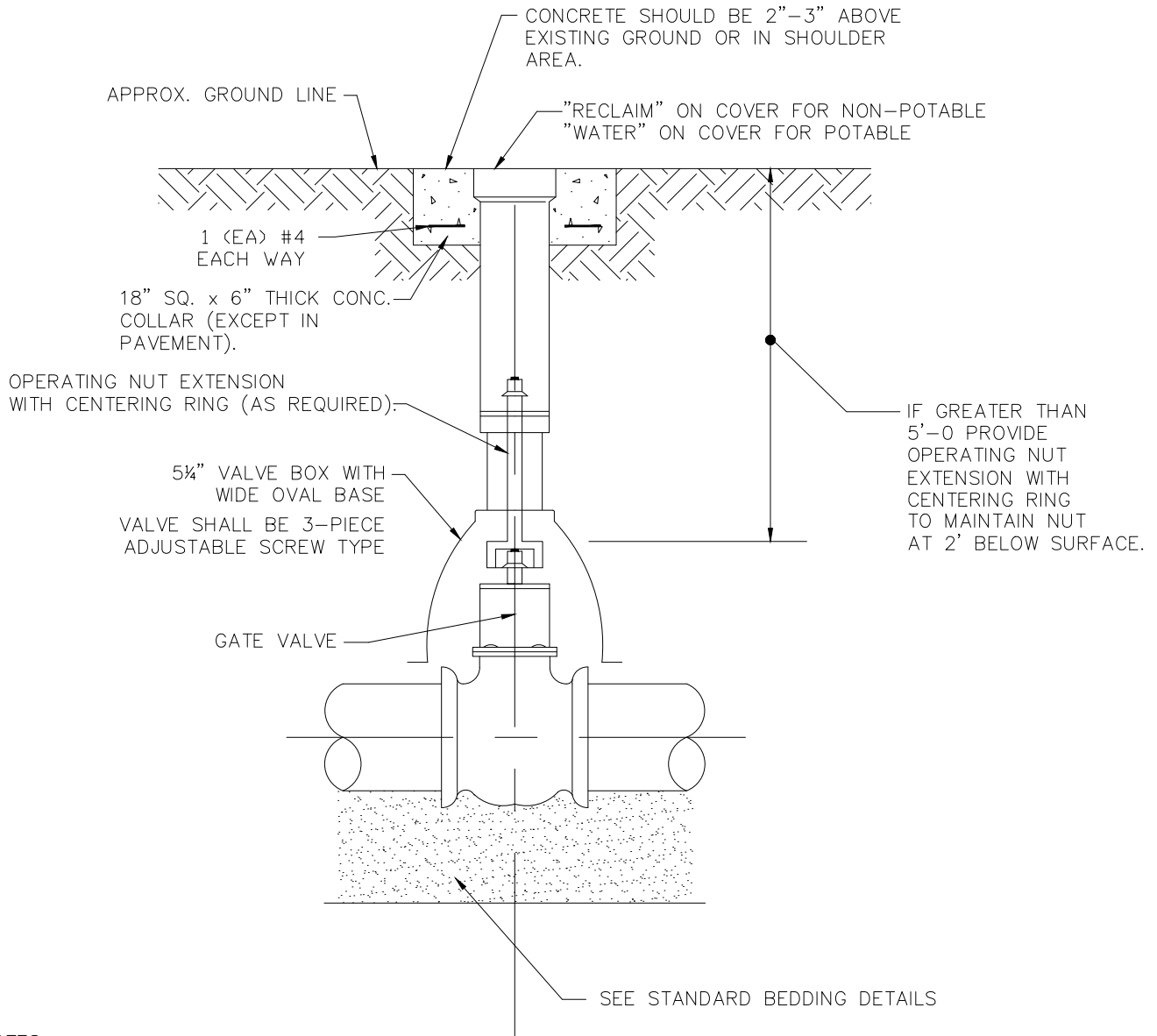

NOTES

1. CARE SHALL BE TAKEN WHEN INSTALLING VALVES TO ASSURE PROPER SUPPORT. 3/4" WASHED ROCK SHALL BE INSTALLED UNDER THE VALVE TO PROVIDE ADDITIONAL SUPPORT WHERE REQUIRED
2. VALVES SHALL NOT BE PLACED IN CONCRETE CROSS PANS, SIDEWALKS, OR UNDER CURB & GUTTER.
3. VALVES & FITTINGS SHALL BE WRAPPED WITH MIN. 8 MIL. THICKNESS POLYETHYLENE WRAP.
4. VALVES ARE OPEN-LEFT.

ACCEPTABLE VALVE BOXES

- A. TYLER SCREW – TYPE "C" CAST IRON VALVE BOX ASSEMBLY SERIES 6860 WITH NO. 160 OVAL BASE
- B. CASTING INC. 6860 SERIES, CI 160B OVAL BASE
- C. STAR PIPE, VB-0006 SERIES

 34501 E. Quincy Ave., Bldg. 34
 WATKINS, COLORADO 80137
 Tel: (303) 292-3456
www.purecyclewwater.com

GATE VALVE

Date: MAY 2018

SHEET No. 48

1. SERVICE LINES WILL NOT BE ACTIVATED UNLESS THE TAP, METER SETTING, AND SERVICE LINE ARE IN COMPLIANCE WITH THE MOST CURRENT VERSION OF THE DESIGN STANDARDS, APPROVED PROJECT DRAWINGS, AND METER INSPECTION WRITTEN INSTRUCTIONS, AS APPLICABLE. DEVIATIONS FROM THESE PLANS AND STANDARDS MUST BE APPROVED IN ADVANCE IN WRITING BY RANGEVIEW.
2. AN ON-SITE PRECONSTRUCTION MEETING WITH A METER INSPECTOR IS REQUIRED FOR TAPS AND SERVICE LINES LARGER THAN 1" AND FOR PROJECTS INVOLVING MORE THAN ONE TAP AND SERVICE. PRECONSTRUCTION MEETINGS MAY BE SCHEDULED BY CALLING THE METER INSPECTION SUPERVISOR AT 303-292-3456.
3. THE METER AND AMR DEVICE LOCATION SHALL BE APPROVED BY RANGEVIEW METER INSPECTION. METER SETTINGS LARGER THAN 1" SHALL BE APPROVED IN THE FIELD BY A METER INSPECTOR PRIOR TO THE INSTALLATION OF ANY SERVICE LINE OR TAP. CALL 303-292-3456 TO MAKE AN APPOINTMENT FOR AN ON-SITE APPROVAL MEETING.
4. METER SETTINGS, SERVICE LINES, AND APPURTENANCES LARGER THAN 1" MUST BE INSPECTED BY A RANGEVIEW METER INSPECTOR BEFORE BEING BACKFILLED.
5. METER PITS AND VAULTS MUST BE SET AND MAINTAINED 1" ABOVE THE FINAL GRADE OF THE LANDSCAPE, WHICH MUST INCLUDE PROPER DEPTH OF SOIL AMENDMENT. IF THE STREET OR GROUND IS NOT TO FINAL GRADE AT THE TIME OF THE METER INSTALLATION OR INSPECTION, THE OWNER MUST RAISE OR LOWER THE METER PIT/VAULT WHEN FINAL GRADE IS ESTABLISHED.
6. PROTECT THE CURB BOXES, METER PITS, AND VAULTS AND AUTOMATIC METER READING DEVICES THROUGHOUT CONSTRUCTION.
7. A BYPASS IS REQUIRED ON POTABLE WATER METERS 1 1/2" AND LARGER. BYPASSES ARE NOT PERMITTED ON IRRIGATION SERVICES.
8. BACKFLOW PREVENTION DEVICES MAY BE REQUIRED IN CONFORMANCE WITH THE DESIGN STANDARDS. IF REQUIRED, THEY MUST BE IN PLACE BEFORE THE FINAL METER INSPECTION.
9. METER PITS SHALL BE FURNISHED WITH PLASTIC FROST LID WITH A 3" DEEP PAN, FIVE DRAIN HOLES, LIFTING HANDLE, AND SLOT FOR AMR WIRE RUNNING FULL DEPTH OF LIP.
10. IN MOST CASES THE AMR DEVICE WILL MOUNT THROUGH THE CAST IRON LID, OR UNDER THE COMPOSITE LID. IN SOME CASES THE REMOTE AMR DEVICE WILL BE REQUIRED. METERS SHALL BE FURNISHED WITH ELECTRONIC DIGITAL ENCODER REGISTERS OR MECHANICALLY ENCODED REGISTERS WITH A REMOTE AMR DEVICE FOR EACH REGISTER.
11. REMOTE AMR DEVICE WILL BE INSTALLED AT A LOCATION DETERMINED BY RANGEVIEW AT THE TIME OF METER INSPECTION. IN MOST CASES, AMR DEVICE WILL BE INSTALLED ON THE OUTSIDE OF THE BUILDING FACING A PUBLIC STREET. OWNER MUST PROVIDE CONDUIT AND SIGNAL WIRE FROM METER TO AMR DEVICE LOCATION.



34501 E. Quincy Ave., Bldg. 34
 WATKINS, COLORADO 80137
 Tel: (303) 292-3456
www.purecyclewater.com

GENERAL METER & SERVICE NOTES

Date: MARCH 2021

SHEET No. 52

RANGEVIEW WATER NOTES

1. EXISTING VALVES IN THE DISTRICT SERVICE AREA MAY ONLY BE OPERATED BY DISTRICT PERSONNEL.
2. BEFORE ANY TAPS ARE MADE TO MAINS, APPLICATION(S) FOR THE TAPS MUST BE RECEIVED AND APPROVED BY THE DISTRICT.
3. IRRIGATION DEMANDS MUST BE FORMALLY SUBMITTED FOR ALL PROJECTS REQUIRING WATER FOR LANDSCAPING PURPOSES.
4. FINAL PLUMBING PLANS MUST BE RECEIVED AND REVIEWED BY THE DISTRICT ENGINEER IN ORDER TO PERFORM FIXTURE UNIT ANALYSIS TO VERIFY TAP SIZE FOR ALL COMMERCIAL, INDUSTRIAL, AND MULTI-FAMILY DEVELOPMENTS.
5. THE CONTRACTOR SHALL BE RESPONSIBLE FOR THE PROCUREMENT OF ALL PERMITS NECESSARY FOR THE CONSTRUCTION OF THE WATER LINE WORK, INCLUDING ANY PERMITS FOR THE DISCHARGE OF GROUNDWATER, CHLORINATED WATER, AND POTABLE OR RECLAIMED WATER THAT MAY BE REQUIRED BY THE WATER QUALITY CONTROL DIVISION OF THE COLORADO DEPARTMENT OF PUBLIC HEALTH AND ENVIRONMENT (CDPHE).
6. ALL WATER MAINS SHALL HAVE A MINIMUM OF FOUR AND ONE-HALF (4-1/2) FEET OF COVER. MAINS ARE TO BE AT LEAST THREE (3) FEET FROM THE EDGE OF THE GUTTER PAN, UNLESS OTHERWISE APPROVED.
7. DISTANCE FOR WATERLINES IS THE HORIZONTAL DISTANCE BETWEEN CENTER OF FITTING TO CENTER OF VALVE, METER, ETC. THEREFORE, THE DISTANCES SHOWN ON THE PLANS ARE APPROXIMATE AND COULD VARY DUE TO VERTICAL ALIGNMENT AT FITTING DIMENSIONS.
8. ALL HYDRANT LATERALS AND FIRE LINES SHALL BE DUCTILE IRON PIPE CLASS 50, FULLY RESTRAINED, AND WITH POLYWRAP.
9. ALL WATER LINE VALVES SHALL BE LOCATED SO THAT THE SURFACE DRAINAGE DOES NOT FLOW INTO THE VALVE BOX.
10. ALL VALVES, VALVE BOXES, CURB STOPS AND/OR METER PIT COVERS SHALL HAVE THE WORD "WATER" STAMPED ON THEM.
11. ALL IRRIGATION AND NON-POTABLE PIPE SHALL BE PURPLE IN COLOR OR SHALL BE LABELED "CAUTION NONPOTABLE WATER" ALONG THE FULL LENGTH OF THE PIPE.
12. ALL DUCTILE IRON PIPE, FITTINGS, VALVES, FIRE HYDRANT BARRELS, AND RESTRAINTS SHALL BE WRAPPED WITH POLYETHYLENE SHEET IN ACCORDANCE WITH AWWA.
13. TRACER WIRE, GAUGE 12 COPPER, SHALL BE INSTALLED ON ALL WATER LINES, FIRE HYDRANTS LATERALS AND APPURTENANCES.
14. UNLESS OTHERWISE APPROVED BY THE DISTRICT, INDIVIDUAL SERVICE LINES SHALL HAVE PRV'S IN ACCORDANCE WITH UNIFORM PLUMBING CODE.
15. AN APPROVED BACKFLOW PREVENTION DEVICE IS REQUIRED ON THE TREATED WATER SERVICE LINE FOR:
 - A. ALL COMMERCIAL AND MULTI-FAMILY DOMESTIC TAPS,
 - B. FIRE LINES
16. ALL POTABLE WATER LINES SHALL BE CHLORINATED IN ACCORDANCE WITH AWWA C-651, "DISINFECTING WATER MAINS."
17. HYDROSTATIC TESTING: ALL WATER LINES SHALL BE HYDROSTATIC TESTED IN ACCORDANCE WITH AWWA C-600 SECTION 4 "HYDROSTATIC TESTING". ALL WATER LINES SHALL BE TESTED TO A MINIMUM OF 150 PSI. THE TEST SHALL BE SCHEDULED WITH THE DISTRICT AND COORDINATED WITH ANY OTHER REVIEWING OR APPROVING AGENCY. THE CONTRACTOR SHALL FURNISH ALL EQUIPMENT FOR TESTING. THE ALLOWABLE LEAKAGE RATES ARE AS FOLLOWS:
$$L = \frac{S \cdot D \cdot (P)^{0.5}}{148,000}$$

L = ALLOWABLE LEAKAGE IN GALLONS PER HOUR
S = TESTED LENGTH OF PIPE, FEET
D = NOMINAL DIAMETER OF PIPE, INCHES
P = AVERAGE TEST PRESSURE DURING THE TEST, PSIG
18. PROBATIONARY ACCEPTANCE OF THE NEW WATER LINES IS CONTINGENT UPON RECEIVING COPIES OF:
 - A. PASSING WATER LINE TRENCH COMPACTION TEST RESULTS;
 - B. PASSING HYDROSTATIC PRESSURE TEST RESULTS;
 - C. RECORD DRAWINGS;
 - D. PASSING CLEAR WATER TESTS;
 - E. FOR RETAIL MAIN EXTENSIONS, A BILL OF SALE TRANSFERRING OWNERSHIP TO THE DISTRICT;
 - F. FINAL EASEMENT AGREEMENTS WHEN APPLICABLE.



34501 E. Quincy Ave., Bldg. 34
WATKINS, COLORADO 80137
Tel: (303) 292-3456
www.purecyclewater.com

WATER NOTES

Date: MARCH 2021

SHEET No. 54

RANGEVIEW WATER NOTES

- 19. ALL MAINS AND SERVICE WATER PIPELINES SHALL BE PLUGGED AT THE END OF EVERY DAY AND BEFORE STORM EVENTS TO PREVENT THE ENTRY OF WATER, MUD, ROCKS, AND OTHER DEBRIS.
- 20. ANY MUD, ROCKS, OR OTHER DEBRIS THAT ENTERS WATER PIPES SHALL BE REMOVED BY THE CONTRACTOR AND THE WATER PIPELINES SHALL BE FLUSHED BY THE CONTRACTOR BEFORE ANY CONTINUATION OF WORK.



34501 E. Quincy Ave., Bldg. 34
WATKINS, COLORADO 80137
Tel: (303) 292-3456
www.purecyclewater.com

WATER NOTES (Continue)

Date: MARCH 2021

SHEET No. 55

NOTES:

1. ALL OUTDOOR METER PITS MUST BE INSTALLED IN LANDSCAPING WITHIN A PUBLIC RIGHT-OF-WAY OR UTILITY EASEMENT. METERS IN LANDSCAPING MUST BE PLACED AT LEAST 3' FROM CENTER OF WATER METER PIT (LID) TO ANY CONCRETE FLATWORK.
2. IF NO TREE LAWN EXISTS, AND THE SIDEWALK IS ADJACENT TO THE BACK OF THE CURB, THE METER SETTING SHALL BE 3' TO 3'-6" FROM THE BACK OF THE SIDEWALK.
3. IF THERE IS A TREE LAWN BETWEEN THE CURB AND SIDEWALK, THE METER SETTING SHALL BE INSTALLED 3' TO 3'-6" AFTER THE SIDEWALK.
4. METER PIT LID ELEVATION SHALL BE 3" HIGHER THAN SIDEWALK TOP EDGE ELEVATION.
5. IF THE METER PIT CANNOT BE INSTALLED IN A LANDSCAPED AREA AND MUST BE PLACED IN A DRIVEWAY OR OTHER LOCATION, PRIOR APPROVAL MUST BE OBTAINED FROM A RANGEVIEW METER INSPECTOR PRIOR TO WATER SERVICE LINE AND METER PIT INSTALLATION.
6. THE METER PIT LID CENTER SHALL BE AT LEAST 5' FROM THE PROPERTY LINE (PL).

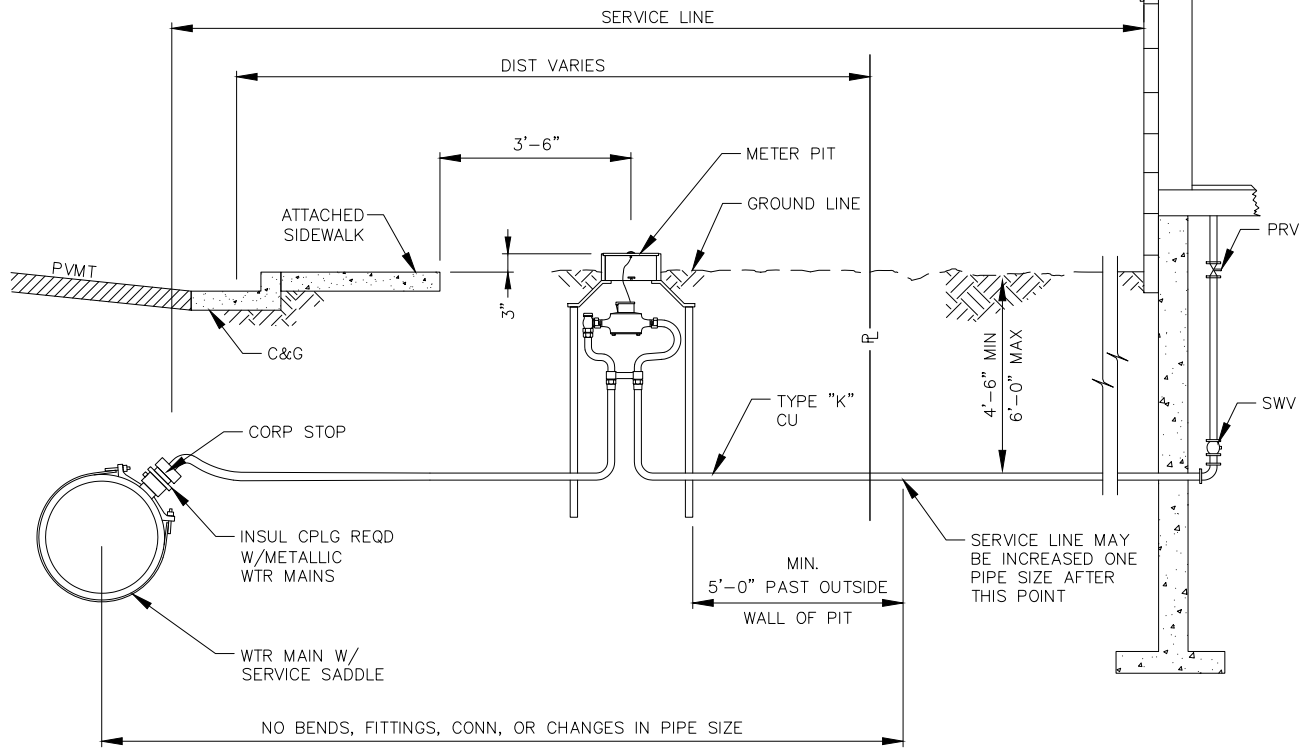

ELEVATION VIEW OF ATTACHED SIDEWALK

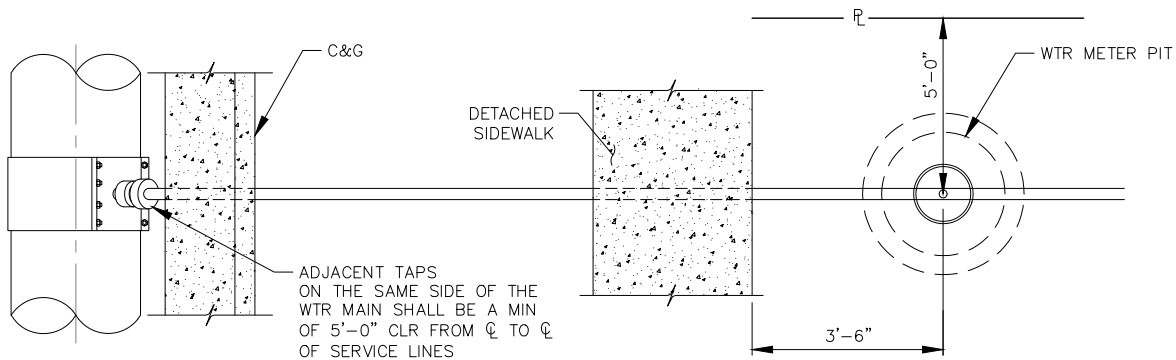

PLAN VIEW OF DETACHED SIDEWALK

Rangeview Metropolitan District
 34501 E. Quincy Ave., Bldg. 34
 WATKINS, COLORADO 80137
 Tel: (303) 292-3456
 www.purecyclewater.com

**2" & SMALLER SERVICE LINE
 & METER**

Date: MARCH 2021

SHEET No. 76

RANGEVIEW METROPOLITAN DISTRICT GENERAL NOTES

1. ALL MAINS, SYSTEM PLANS AND CONSTRUCTION SHALL CONFORM TO THE RANGEVIEW METROPOLITAN DISTRICT (THE DISTRICT) SPECIFICATIONS AND SHALL BE SUBJECT TO CONSTRUCTION OBSERVATION BY DISTRICT PERSONNEL. ALL MATERIAL AND WORKMANSHIP SHALL BE IN CONFORMANCE WITH DISTRICT SPECIFICATIONS AND STANDARDS.
2. THE CONTRACTOR SHALL SCHEDULE A PRECONSTRUCTION MEETING WITH THE DISTRICT AT LEAST 48 HOURS PRIOR TO THE START OF CONSTRUCTION. PLANS WITH THE DISTRICT REVIEW STAMP WILL BE DISTRIBUTED PRIOR TO OR AT THE PRECONSTRUCTION MEETING. NO CONSTRUCTION WILL BE PERMITTED UNTIL FORMAL RECORDING OF EASEMENTS IS COMPLETE. NO CONSTRUCTION WILL BE PERMITTED PRIOR TO THE PRECONSTRUCTION MEETING.
3. ALL WATER MAINS INSTALLED SHALL CONFORM TO DISTRICT MATERIAL SPECIFICATIONS.

DUCTILE IRON PIPE	AWWA C151 CLASS 50 WITH POLYWRAP
POLYVINYL CHLORIDE (PVC)	AWWA C900 DR18
4. THE APPROVAL OF THE CONSTRUCTION PLANS SIGNIFIES ONLY THAT THE PLANS MEET THE MINIMUM REQUIREMENTS OF THE DISTRICT'S STANDARDS AND SPECIFICATIONS BASED ON THE INFORMATION PROVIDED. APPROVAL IS NOT A REPRESENTATION OR WARRANTY THAT THE SYSTEM AND ASSOCIATED COMPONENTS WILL PERFORM ANY CERTAIN FUNCTIONS.
5. OBSERVATION OF WORK IN PROGRESS AND ON-SITE VISITS ARE NOT TO BE CONSTRUED AS A GUARANTEE BY THE DISTRICT OF THE CONTRACTOR'S CONTRACTUAL COMMITMENT.
6. THE DISTRICT IS NOT RESPONSIBLE FOR SAFETY IN, ON, OR ABOUT THE PROJECT SITE, NOR FOR COMPLIANCE OF ANY REGULATIONS RELATING THERETO.
7. THE CONTRACTOR SHALL ASSUME SOLE AND COMPLETE RESPONSIBILITY FOR JOB SITE CONDITIONS DURING THE COURSE OF CONSTRUCTION OF THE PROJECT, INCLUDING SAFETY OF ALL PERSONS AND PROPERTY; THAT THIS REQUIREMENT SHALL APPLY CONTINUOUSLY, AND NOT BE LIMITED TO NORMAL WORKING HOURS; AND THAT THE CONTRACTOR SHALL DEFEND, INDEMNIFY AND HOLD HARMLESS FROM ANY AND ALL LIABILITY, REAL OR ALLEGED, IN CONNECTION WITH THE PERFORMANCE OF WORK ON THIS PROJECT, EXCEPTING FOR LIABILITY ARISING FROM THE SOLE NEGLIGENCE OF THE DISTRICT.
8. THE CONTRACTOR IS RESPONSIBLE FOR:
 - A. NOTIFYING ALL CUSTOMERS POSSIBLY AFFECTED BY OUTAGE OF WATER OR SEWER SERVICE DURING CONSTRUCTION PRIOR TO SHUTTING OFF SAID SERVICE.
 - B. OBTAINING, AT THE CONTRACTOR'S EXPENSE, ALL APPLICABLE LICENSES, PERMITS, BONDS, ETC. REQUIRED FOR MAIN INSTALLATION/SYSTEM MODIFICATIONS.
 - C. CONTACTING THE DISTRICT FOR A PRE-CONSTRUCTION MEETING AT (303) 292-3456.
 - D. NOTIFYING THE DISTRICT 48 HOURS IN ADVANCE OF ANY NEEDS TO SHUT DOWN ANY PORTION OF THE EXISTING WATER AND/OR SANITARY SEWER SYSTEM.
 - E. NOTIFYING THE DISTRICT 48 HOURS IN ADVANCE FOR CONSTRUCTION OBSERVATIONS.
 - F. IN CASE OF AN EMERGENCY AFTER WORKING HOURS CALL THE DISTRICT OFFICE AT (303) 292-3456 FOR RECORDED INSTRUCTIONS.
9. THE DISTRICT ASSUMES NO RESPONSIBILITY FOR UTILITY LOCATIONS. THE CONTRACTOR IS RESPONSIBLE TO FIELD VERIFY THE LOCATION OF ALL UTILITIES PRIOR TO THE COMMENCEMENT OF ANY CONSTRUCTION. THE CONTRACTOR SHALL BE RESPONSIBLE FOR THE PROTECTION OF ALL UTILITY LINES WHETHER SHOWN ON THE PLANS OR NOT. THE CONTRACTOR SHALL COORDINATE HIS/HER ACTIVITIES WITH THE AFFECTED UTILITY COMPANIES AND SHALL NOTIFY THE UTILITY NOTIFICATION CENTER IN ACCORDANCE WITH STATE AND LOCAL REGULATIONS.
10. CONTRACTOR SHALL PERFORM POTHOLING ON EXISTING UTILITIES PRIOR TO THE CONSTRUCTION OF THE WATER AND/OR SANITARY SEWER LINES AND THIS SHALL BE CONSIDERED INCIDENTAL TO THE INSTALLATION COST OF THE PIPELINE.
11. THE CONTRACTOR SHALL HAVE IN HIS/HER POSSESSION AT ALL TIMES ONE (1) COPY OF THE PROJECT PLANS SIGNED BY THE DISTRICT.
12. THE CONTRACTOR SHALL BE RESPONSIBLE FOR REMOVING AND REPLACING ANY EXISTING SIGNS, STRUCTURES, FENCES, ETC ENCOUNTERED ON THE JOB AND RESTORING THEM TO THEIR ORIGINAL CONDITION.
13. THE CONTRACTOR SHALL BE RESPONSIBLE FOR REMOVING ANY GROUNDWATER ENCOUNTERED DURING THE CONSTRUCTION OF ANY PORTION OF THIS PROJECT. GROUNDWATER SHALL BE PUMPED, PIPED, REMOVED AND DISPOSED OF IN ACCORDANCE WITH REQUIREMENTS OF THE COLORADO DISCHARGE ELIMINATION SYSTEM ADMINISTERED BY THE WATER QUALITY CONTROL DIVISION OF CDPHE IN A MANNER WHICH DOES NOT CAUSE FLOODING OF EXISTING STREETS NOR EROSION ON ABUTTING PROPERTIES. USE OF THE DISTRICT'S SEWER SYSTEM FOR THE DISPOSAL OF GROUND WATER IS PROHIBITED WITHOUT WRITTEN CONSENT FROM THE DISTRICT. ANY UNSTABLE AREAS, AS A RESULT OF GROUNDWATER, ENCOUNTERED DURING THE CONSTRUCTION OF THE PROPOSED IMPROVEMENTS SHALL BE STABILIZED AS AGREED UPON BY THE DISTRICT AND THE DESIGN ENGINEER AT THE TIME OF THE OCCURRENCE.



34501 E. Quincy Ave., Bldg. 34
WATKINS, COLORADO 80137
Tel: (303) 292-3456
www.purecyclewater.com

GENERAL NOTES

Date: MAY 2018

SHEET No. 77

RANGEVIEW METROPOLITAN DISTRICT GENERAL NOTES

- 14. IT SHALL BE THE DESIGN ENGINEER'S RESPONSIBILITY TO RESOLVE CONSTRUCTION PROBLEMS DUE TO CHANGED CONDITIONS ENCOUNTERED DURING THE PROGRESS OF ANY PORTION OF THE PROPOSED WORK WITH THE DISTRICT. IF, IN THE OPINION OF THE DISTRICT, PROPOSED ALTERATIONS TO THE SIGNED CONSTRUCTION PLANS INVOLVES SIGNIFICANT CHANGES TO THE CHARACTER OF THE WORK, OR TO FUTURE CONTIGUOUS PUBLIC OR PRIVATE IMPROVEMENTS, THE DESIGN ENGINEER SHALL BE RESPONSIBLE FOR SUBMITTING REVISED PLANS TO THE DISTRICT FOR REVIEW PRIOR TO ANY FURTHER CONSTRUCTION RELATED TO THAT PORTION OF THE WORK.
- 15. THE OWNER IS RESPONSIBLE FOR ALL COSTS ASSOCIATED WITH PLAN REVIEW AND CONSTRUCTION OBSERVATION.
- 16. MAINTAIN MINIMUM OF 10 FEET SEPARATION BETWEEN POTABLE AND NON-POTABLE WATER AND SANITARY SEWER MAINS AND SERVICES IN ACCORDANCE WITH CDPHE STANDARDS.
- 17. THE CONTRACTOR WILL BE REQUIRED TO PROVIDE A TRAFFIC CONTROL PLAN TO THE APPROPRIATE JURISDICTION (ARAPAHOE COUNTY OR CDOT) PRIOR TO ISSUANCE OF A STREET CUT/ROW USE PERMIT.
- 18. SHOP DRAWINGS FOR ALL PIPES, FITTINGS, AND APPURTENANCES SHALL BE SUBMITTED AT LEAST 48 HOURS PRIOR TO THE INSTALLATION.



34501 E. Quincy Ave., Bldg. 34
WATKINS, COLORADO 80137
Tel: (303) 292-3456
www.purecyclewater.com

GENERAL NOTES (Continue)

Date: MAY 2018

SHEET No. 78

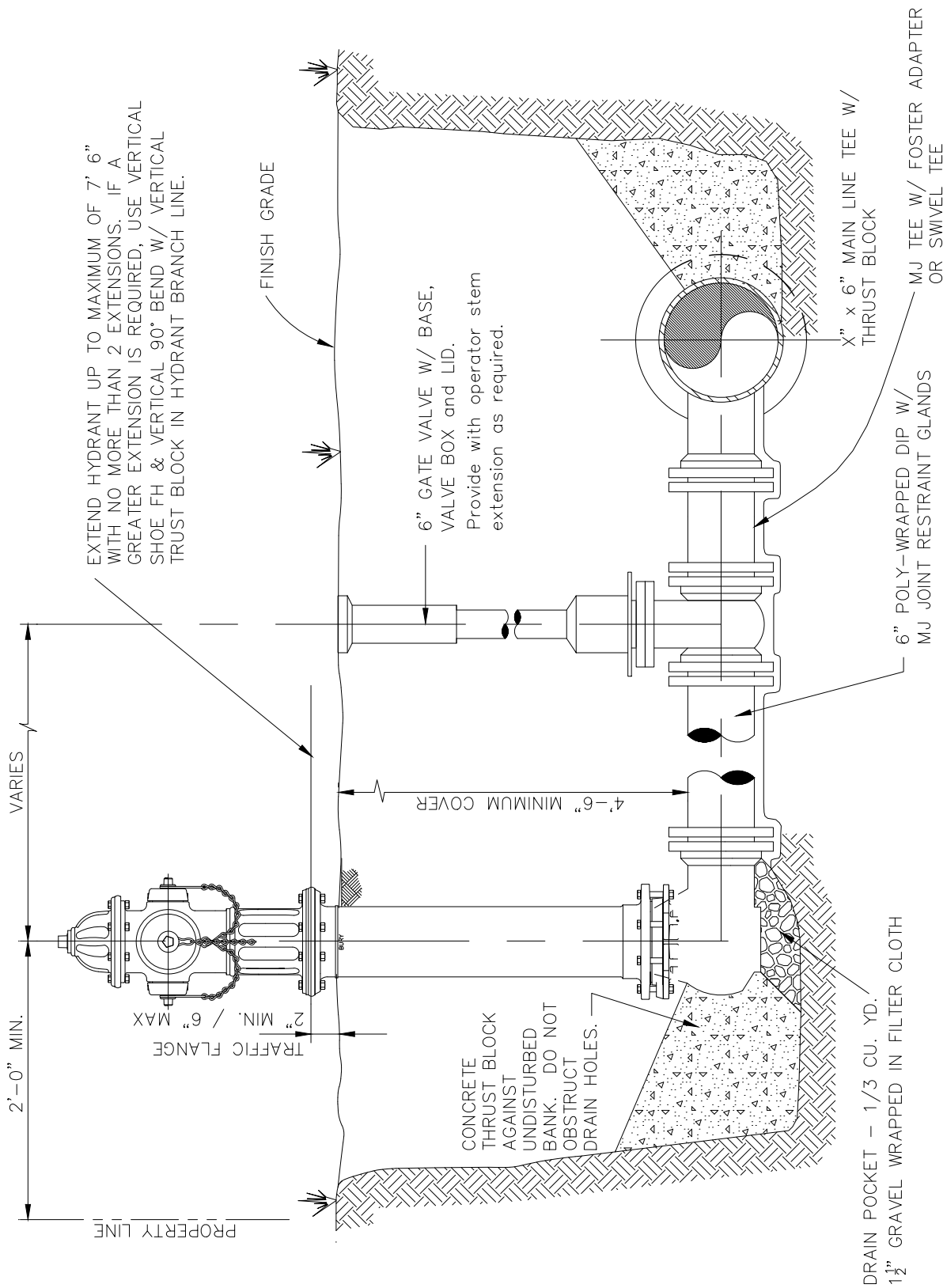

NOTES:

1. HYDRANT IS OPEN LEFT.
2. ALIGN FIRE HYDRANT AS DIRECTED BY FIRE PROTECTION DISTRICT.
3. POLYWRAP ALL DIP & STEEL FITTINGS, VALVES & ACCESSORIES.



34501 E. Quincy Ave., Bldg. 34
 WATKINS, COLORADO 80137
 Tel: (303) 292-3456
 www.purecyclewater.com

STANDARD FIRE HYDRANT

Date: MAY 2018

SHEET No. 79

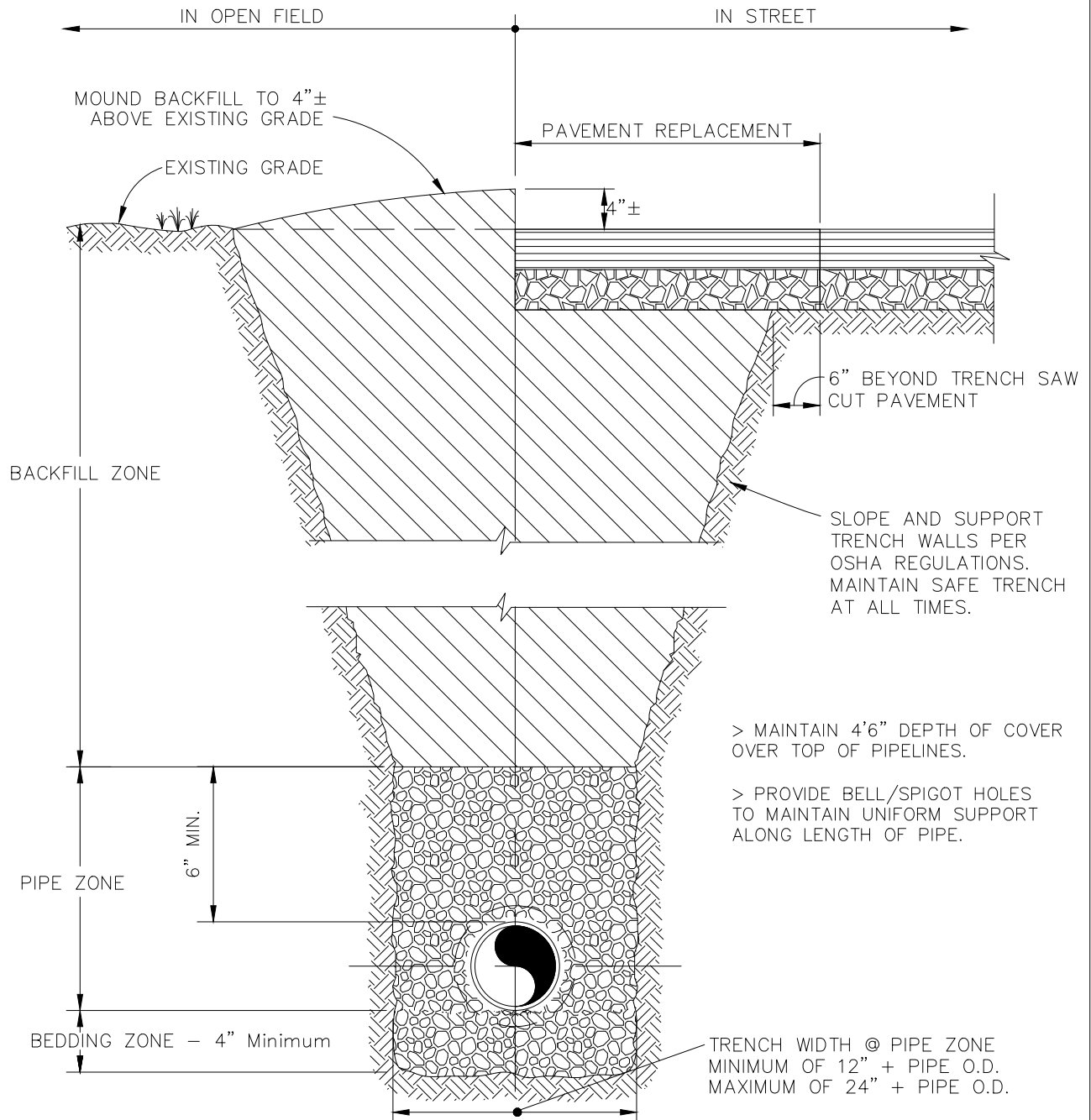

ZONE	MATERIAL SPECIFICATIONS	MINIMUM COMPACTION REQUIREMENTS	MAXIMUM LIFT THICKNESS
BACKFILL	Select Excavated Materials	Open Field: 90% Standard Proctor	24"
		Roads: 95% Standard Proctor (ASTM D698)	8"
PIPE ZONE AND BEDDING	Well-Graded Sand, Class 6 Roadbase, or Grannular Mat'l	> Water and Sewers to 12' Depth - 70% Relative Density (ASTM D2049) > Sewers deeper than 12' - 75% Relative Density	6" except 1st lift <= 1/2 pipe diameter



34501 E. Quincy Ave., Bldg. 34
WATKINS, COLORADO 80137
Tel: (303) 292-3456
www.purecyclewater.com

PIPELINE TRENCH

Date: MAY 2018

SHEET No. 80

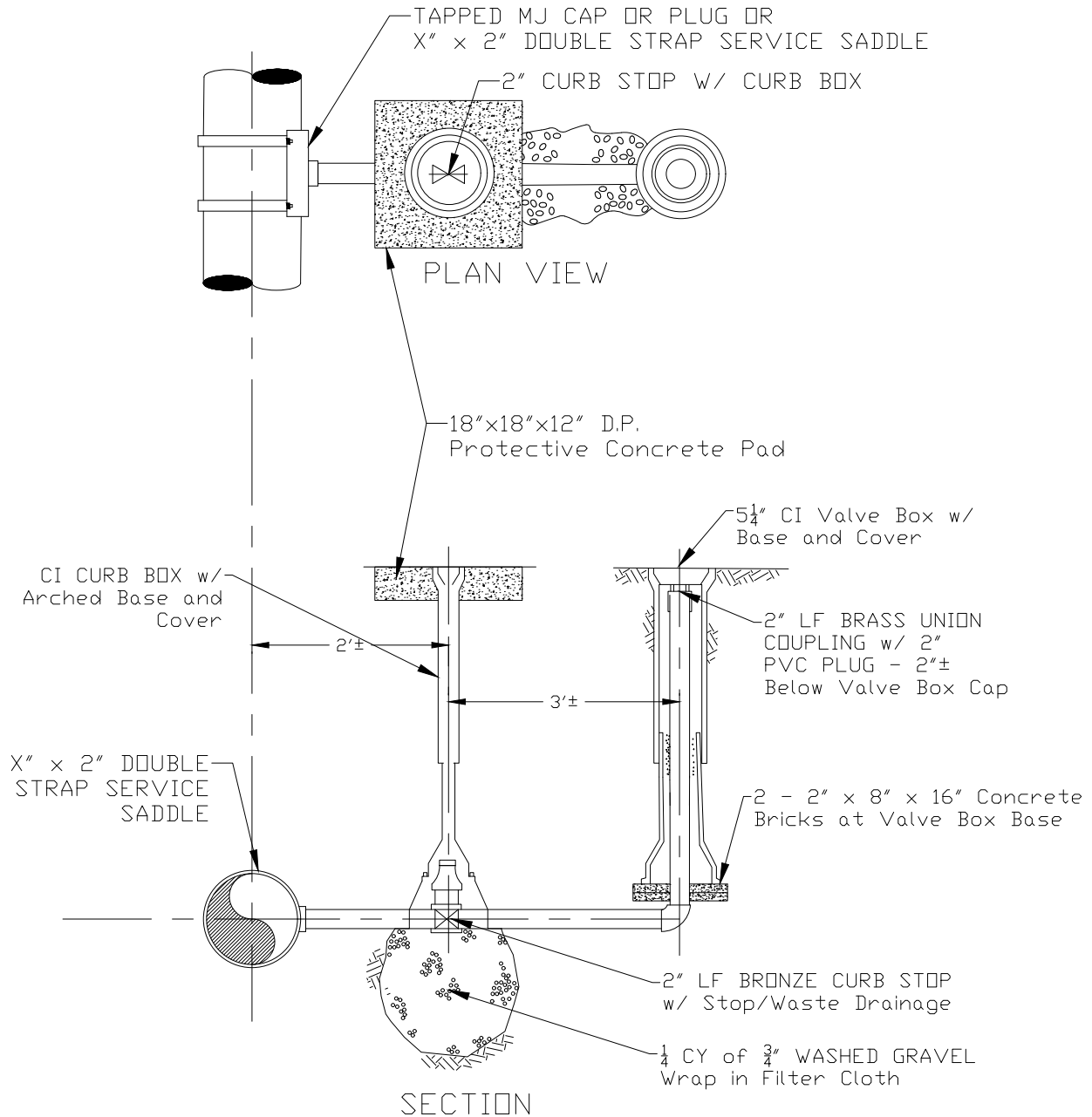

34501 E. Quincy Ave., Bldg. 34
WATKINS, COLORADO 80137
Tel: (303) 292-3456
www.purecyclewater.com

2" BLOWOFF

Date: MAY 2018

SHEET No. 81

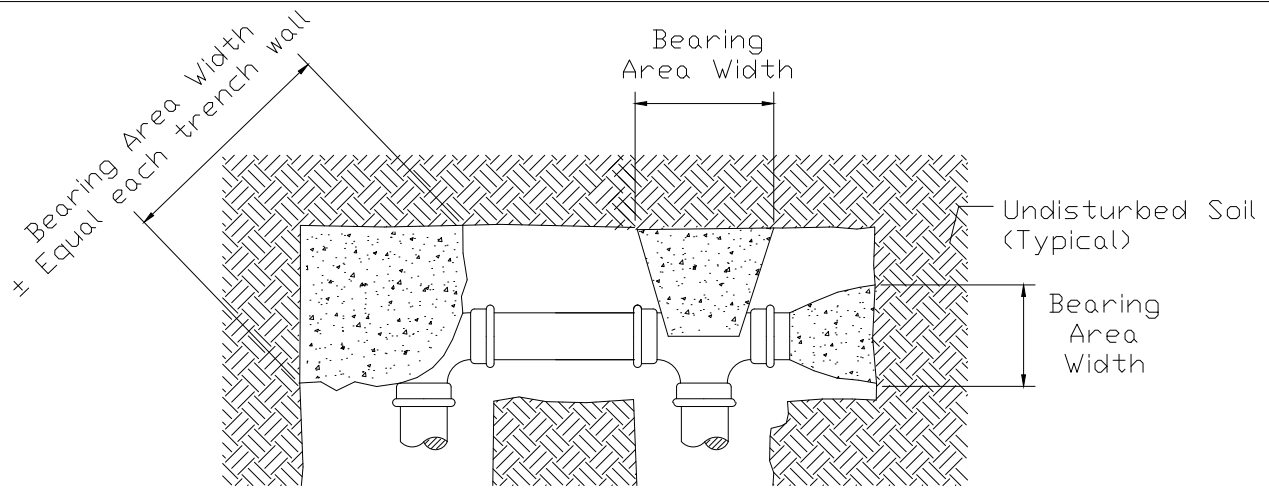

NOTES:

1. Mechanical Joint Restraint Glands Req'd but not shown for clarity.
2. Poly-wrap all ferrous piping, fittings and joint restraints.
3. Shape and form thrust blocks such that All joints and bolts are accessible.
4. Restrain pipe from each side of fittings & valves.

Concrete (3,000 psi Minimum
28-day compressive strength)

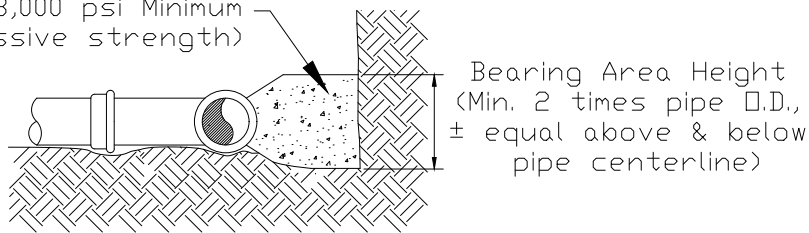

MINIMUM THRUST BLOCK BEARING AREA [SQ-FT]					
PIPE SIZE	BENDS				TEE, PLUG, OR CAP
	11¼°	22½°	45°	90°	
4"	0.2	0.4	0.8	1.9	1.3
6"	0.4	0.8	1.6	3.9	2.8
8"	0.7	1.3	2.8	6.8	4.8
12"	1.4	2.9	6.0	14.4	10.2
16"	2.5	5.0	10.3	25.0	17.7
24"	5.4	10.9	22.7	54.9	38.8

MINIMUM LENGTH OF RESTRAINED PIPE [FT]					
PIPE SIZE	BENDS				TEE, PLUG, OR CAP
	11¼°	22½°	45°	90°	
4"	1	2	4	9	26
6"	1	3	5	13	38
8"	2	3	7	17	49
12"	2	5	10	24	70
16"	3	6	13	31	91
24"	4	9	18	44	132

BASED ON 2,000 PSF SOIL BEARING PRESSURE AND 150 PSIG
MAXIMUM HYDROSTATIC TEST PRESSURE. MAY BE ADJUSTED
DOWN WHERE LOWER TEST PRESSURE APPLY.



34501 E. Quincy Ave., Bldg. 34
WATKINS, COLORADO 80137
Tel: (303) 292-3456
www.purecyclewater.com

THRUST RESTRAINT

Date: MARCH 2021

SHEET No. 82

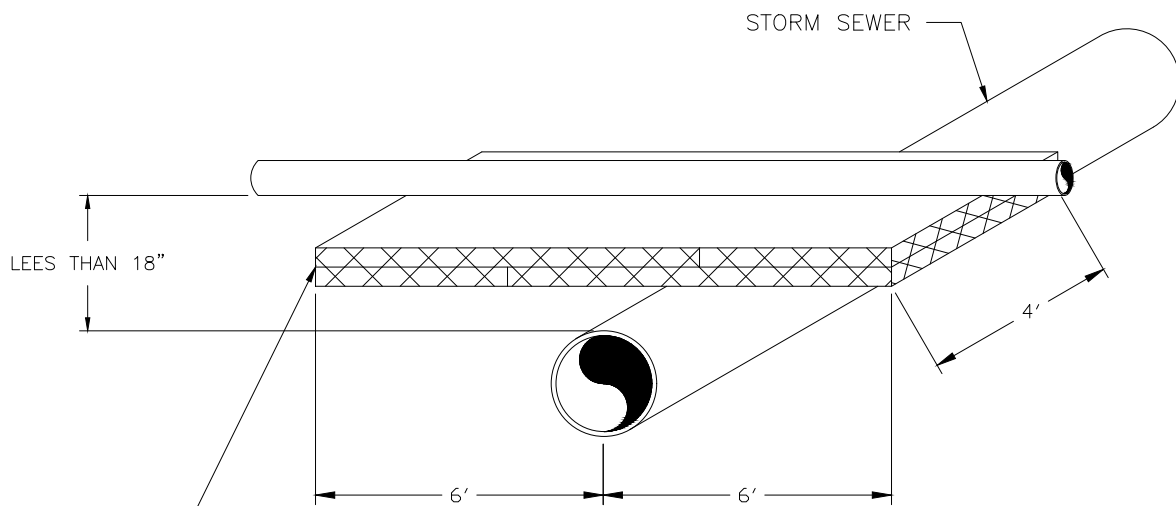

TWO LAYERS 2" EXTRUDED POLYSTYRENE 4' WIDE
 EXTENDING 6' EACH SIDE OF CROSSING & VERTICALLY
 CENTERED BETWEEN THE TWO PIPES. STAGGER JOINTS.

NOTE:

SIMILAR FOR WATER PIPELINE CROSSING BELOW STORM SEWER WITH LESS THAN 18" CLEARANCE.



34501 E. Quincy Ave., Bldg. 34
 WATKINS, COLORADO 80137
 Tel: (303) 292-3456
 www.purecyclewater.com

INSULATED CROSSING

Date: MAY 2018

SHEET No. 83

LOCATION OF WATER SERVICE TAPS:

FOR 12-INCH OR SMALLER PIPE, THE TAP SHALL NOT BE LOCATED CLOSER THAN 24 INCHES FROM:

- THE BACK OF THE BELL (WHERE THE BELL TRANSITIONS TO THE BARREL OF THE PIPE)
- THE SPIGOT INSERTION LINE
- JOINT-RESTRAINT HARDWARE

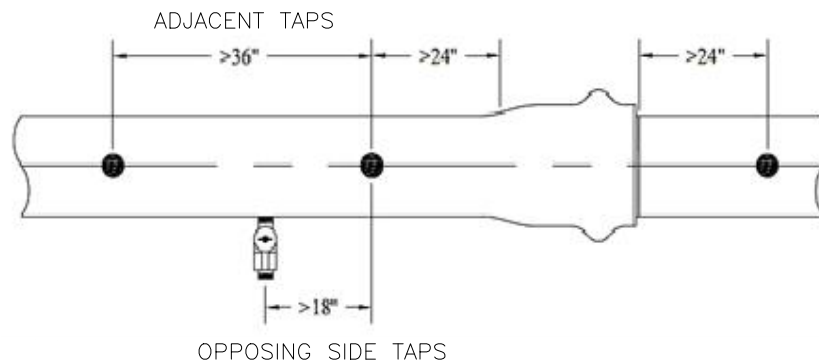

PVC PIPE DEFLECTION:

1. PIPE BENDING – SOME CHANGES IN DIRECTION MAY BE ACCOMPLISHED WITHOUT THE USE OF BENDS, SWEEPS, OR OTHER FITTINGS. CONTROLLED BENDING WITHIN ACCEPTABLE LIMITS CAN BE ACCOMMODATED BY PVC PIPE. A GENERAL RULE OF THUMB FOR THE MINIMUM BENDING RADIUS (RB) CALCULATION IS $RB = 250 OD$. TIGHTER BENDING RADII MAY BE ACHIEVED FOR CERTAIN PRODUCTS. CONSULT THE MANUFACTURER FOR SPECIFIC PRODUCT INFORMATION. IN MOST CASES, BENDING SHOULD BE ACCOMPLISHED MANUALLY. IT IS NOT RECOMMENDED TO ATTEMPT BENDING PIPES GREATER THAN 12" IN DIAMETER DUE TO THE FORCES REQUIRED.
2. JOINT DEFLECTION – CHANGES IN DIRECTION MAY ALSO BE ACCOMPLISHED THROUGH JOINT DEFLECTION. ALLOWABLE JOINT DEFLECTION IS DEPENDENT ON PIPE SIZE AND JOINT DESIGN. JOINT DEFLECTION LIMITS SHOULD BE OBTAINED FROM THE PIPE MANUFACTURER.
3. COMBINED PIPE BENDING AND JOINT DEFLECTION – EITHER JOINT DEFLECTION OR LONGITUDINAL BENDING MAY BE USED FOR CHANGES IN DIRECTION, BUT NOT BOTH ON THE SAME LENGTH OF PIPE.



34501 E. Quincy Ave., Bldg. 34
WATKINS, COLORADO 80137
Tel: (303) 292-3456
www.purecyclewater.com

PVC PIPE DEFLECTION AND TAP LOCATION

Date: MARCH 2021

SHEET No. 90

RANGEVIEW SANITARY SEWER NOTES

1. THE CONTRACTOR SHALL BE RESPONSIBLE FOR THE PROCUREMENT OF ALL PERMITS NECESSARY FOR THE CONSTRUCTION OF THE SANITARY SEWER LINE WORK.
2. THE CONTRACTOR IS RESPONSIBLE FOR:
 - A. NOTIFYING THE DISTRICT 48 HOURS IN ADVANCE OF ANY NEED TO SHUT DOWN ANY PORTION OF THE EXISTING SANITARY SEWER SYSTEM.
 - B. NOTIFYING THE DISTRICT 48 HOURS IN ADVANCE OF THE WORK.
 - C. IN CASE OF AN EMERGENCY AFTER WORKING HOURS, CALL THE DISTRICT OFFICE AT (303) 292-3456 FOR RECORDED INSTRUCTIONS.
3. UNDERDRAINS ARE NOT PART OF THE SANITARY SEWER LINES OR SYSTEM AND WILL NOT BE ALLOWED IN THE SAME TRENCH AS THE SANITARY SEWER MAINS. UNDERDRAINS SHALL NOT BE ACCEPTED, MAINTAINED OR SUBJECT TO CONSTRUCTION OBSERVATION BY THE DISTRICT. THE DISTRICT HAS NO SPECIFICATIONS FOR UNDERDRAINS AND WILL ONLY REVIEW THEIR PROPOSED LOCATION RELATIVE TO THE SANITARY SEWER LINES.
4. THE CONTRACTOR SHALL VERIFY EXISTING MANHOLE INVERTS TO BE CONNECTED TO PRIOR TO CONSTRUCTION STAKING AND CONSTRUCTION.
5. LENGTH OF SANITARY SEWER IS THE HORIZONTAL DISTANCE BETWEEN CENTERS OF MANHOLE. THEREFORE DISTANCES SHOWN ON THE PLANS ARE APPROXIMATE AND COULD VARY DUE TO VERTICAL ALIGNMENT AND MANHOLE DIMENSIONS.
6. PIPE USED FOR SANITARY SEWER MAINS SHALL BE IN ASTM D-3034 SDR 35 PVC EXCEPT. AWWA C-900 CLASS 165 (DR25) SHALL BE USED AS NOTED ON THE PROJECT PLANS AND DISTRICT DETAILS.
7. MANHOLE RIMS SHALL BE SET AT AN ELEVATION RELATIVE TO THE PAVEMENT, IN ACCORDANCE WITH COUNTY STANDARDS. WHETHER THE MANHOLE IS IN A PAVED OR UNPAVED GRADE, A MAXIMUM ACCEPTABLE VERTICAL ADJUSTMENT UTILIZING CONCRETE RINGS IS TWELVE (12) INCHES.
8. THE CONTRACTOR SHALL TAKE CARE TO PROPERLY SHAPE ALL MANHOLE INVERTS AND BENCHES IN ACCORDANCE, TO PROMOTE SMOOTH FLOW THROUGH THE MANHOLE. INVERTS OF LINES INTERSECTING AT 90 DEGREES AND AT HIGHLY DIVERGENT OR FLAT SLOPES ARE ESPECIALLY CRITICAL. MANHOLE INVERTS SHALL BE CONSTRUCTED WITH A SMOOTH TROWEL FINISH, AND BENCHES FINISHED WITH A LIGHT BROOM, NON-SKID FINISH.
9. SANITARY SEWER SERVICES SHALL BE STUBBED OUT. THE END OF THE STUB SHALL BE WITNESSED BY A WOOD, CARBONITE OR METAL POST AT LEAST FOUR FEET LONG, BURIED TO EXPOSE ONE FOOT. THE CONTRACTOR SHALL FURNISH AS-BUILT LOCATION OF THE WYE.
10. THE SANITARY SEWER SYSTEM SHALL BE TESTED IN ACCORDANCE WITH THE DISTRICT STANDARDS AND SPECIFICATIONS.
 - A. EXFILTRATION OR LOW PRESSURE AIR TEST 100% OF THE NEW SYSTEM, AND
 - B. DEFLECTION TEST, AT A MINIMUM 33% OF SEWERS FIFTEEN (15) FEET OR LESS IN DEPTH, AND 100% OF SEWERS GREATER THAN FIFTEEN (15) FEET IN DEPTH.
 - C. TV/VIDEO TAPE 100% OF THE SYSTEM.
11. PROBATIONARY ACCEPTANCE OF THE NEW SANITARY SEWER MAINS IS CONTINGENT UPON RECEIVING COPIES OF:
 - A. PASSING TRENCH COMPACTION TEST RESULTS,
 - B. RECORD DRAWINGS, AND
 - C. COMPLETION OF SYSTEM TESTING.
12. CONNECTIONS TO EXISTING DISTRICT LINES WILL BE PERMITTED UPON ACCEPTANCE OF THE NEW SANITARY SEWER SYSTEM. EXISTING PIPE AT THE POINT OF CONNECTION SHALL NOT BE "BROKEN OUT" UNTIL THE NEW SYSTEM IS ACCEPTED.
13. MONITORING MANHOLES ARE REQUIRED FOR ALL COMMERCIAL AND INDUSTRIAL SANITARY SERVICE LINES.
14. ALL SANITARY SEWERS NOT TERMINATING AT A COMPLETED MANHOLE SHALL BE PLUGGED AT THE END OF EVERY DAY AND BEFORE STORM EVENTS TO PREVENT THE ENTRY OF WATER, MUD, ROCKS, OR OTHER DEBRIS.
15. ANY MUD, ROCKS, OR OTHER DEBRIS THAT ENTER SANITARY SEWER PIPES AND MANHOLES, SHALL BE REMOVED BY CONTRACTOR BEFORE ANY CONTINUATION OF WORK.



SANITARY SEWER NOTES

Date: MARCH 2021

SHEET No. 100

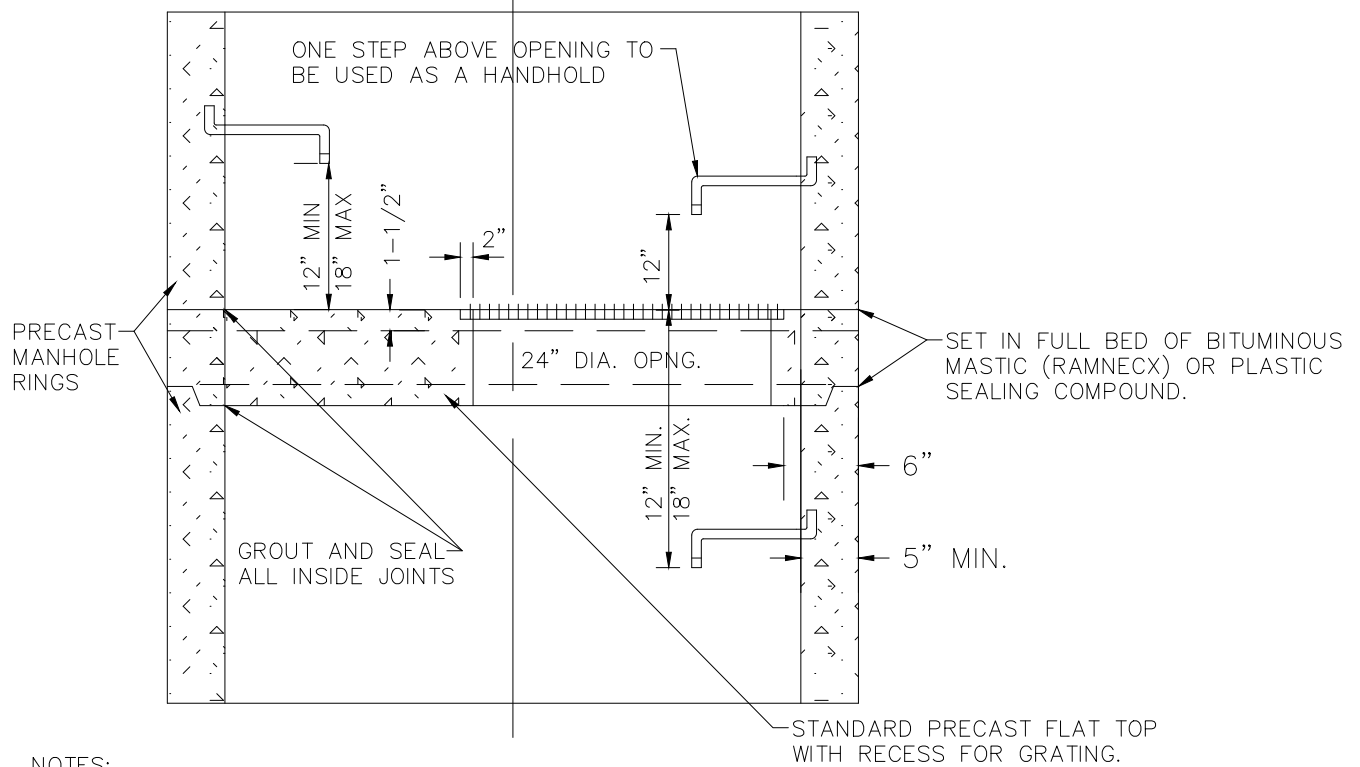
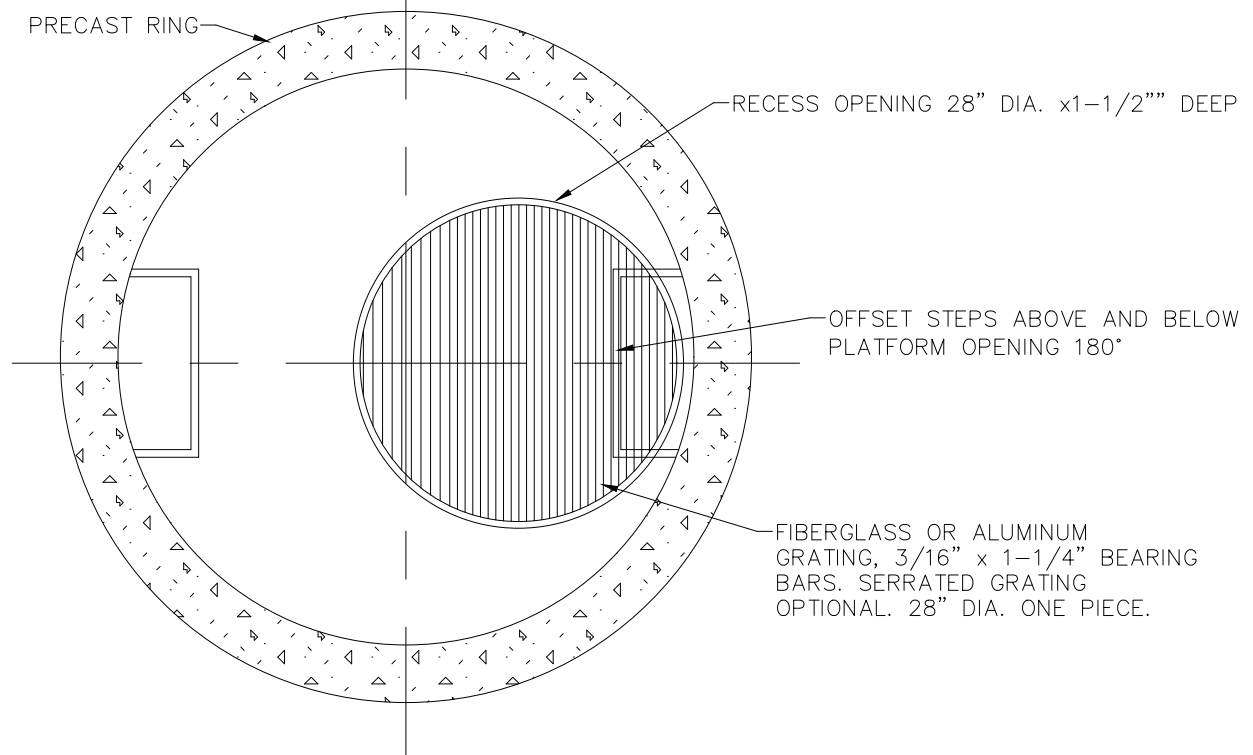

NOTES:

1. REQUIRED IN MANHOLES WHERE DEPTH MEASURED FROM RING AND COVER TO THE INVERT EXCEEDS 20 FEET.
2. VERTICALLY CENTER FLATTOP PLATFORM BETWEEN RING AND COVER AND MANHOLE INVERT.

	34501 E. Quincy Ave., Bldg. 34 WATKINS, COLORADO 80137 Tel: (303) 292-3456 www.purecyclegwater.com
INTERMEDIATE PLATFORM FOR MANHOLE GREATER THAN 20' DEEP	
Date: MARCH 2021	SHEET No. 102

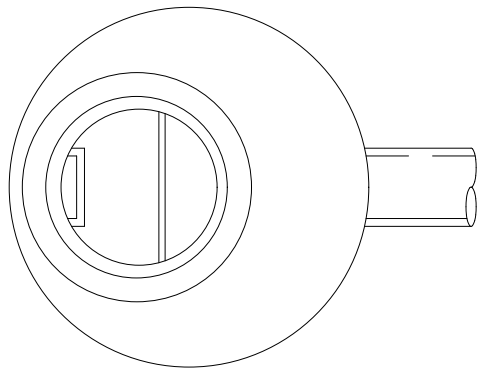

RING AND COVER ELEVATION SHALL COMPLY WITH THE CITY/ COUNTY REQUIREMENTS.

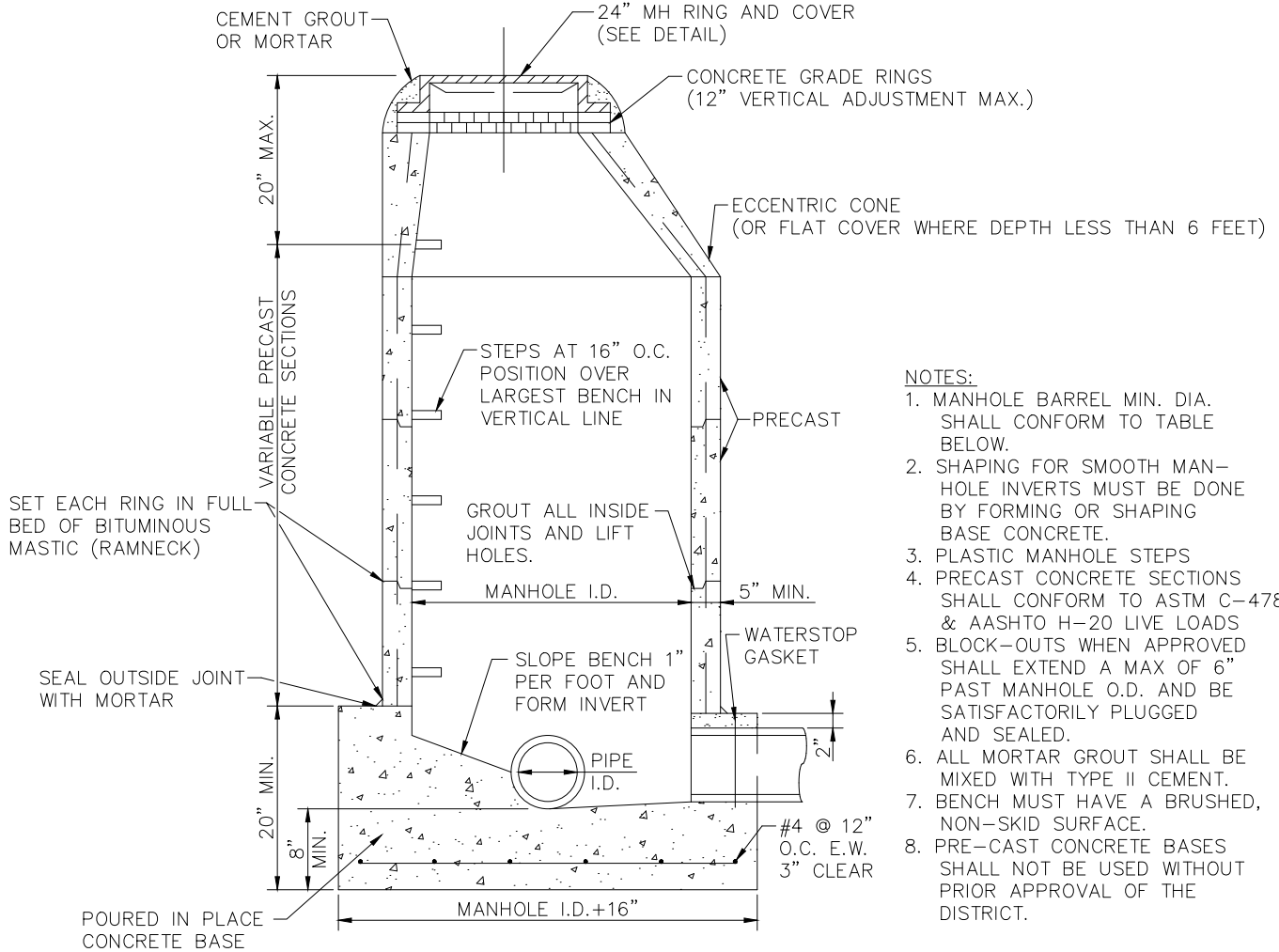

NOTES:

1. MANHOLE BARREL MIN. DIA. SHALL CONFORM TO TABLE BELOW.
2. SHAPING FOR SMOOTH MANHOLE INVERTS MUST BE DONE BY FORMING OR SHAPING BASE CONCRETE.
3. PLASTIC MANHOLE STEPS
4. PRECAST CONCRETE SECTIONS SHALL CONFORM TO ASTM C-478, & AASHTO H-20 LIVE LOADS
5. BLOCK-OUTS WHEN APPROVED SHALL EXTEND A MAX OF 6" PAST MANHOLE O.D. AND BE SATISFACTORILY PLUGGED AND SEALED.
6. ALL MORTAR GROUT SHALL BE MIXED WITH TYPE II CEMENT.
7. BENCH MUST HAVE A BRUSHED, NON-SKID SURFACE.
8. PRE-CAST CONCRETE BASES SHALL NOT BE USED WITHOUT PRIOR APPROVAL OF THE DISTRICT.

PIPE I.D.	MANHOLE I.D.	RING & COVER
18" & SMALLER	4'-0"▲	24"
21" TO 48"	5'-0"	30"
SEE NOTE	6'-0"	30"

▲ WHENEVER MORE THAN A TWO WAY MANHOLE OF MAX. PIPE I.D. IS REQUIRED, THE MANHOLE SHOULD BE INCREASED TO LARGER DIA., EG. 18"x18"x18", REQUIRES 5'-0" I.D.

NOTE: USE ONE-SIZE LARGER MANHOLE FOR INSIDE-DROP MANHOLES



34501 E. Quincy Ave., Bldg. 34
 WATKINS, COLORADO 80137
 Tel: (303) 292-3456
 www.purecyclegwater.com

PRECAST MANHOLE

Date: MAY 2018

SHEET No. 103

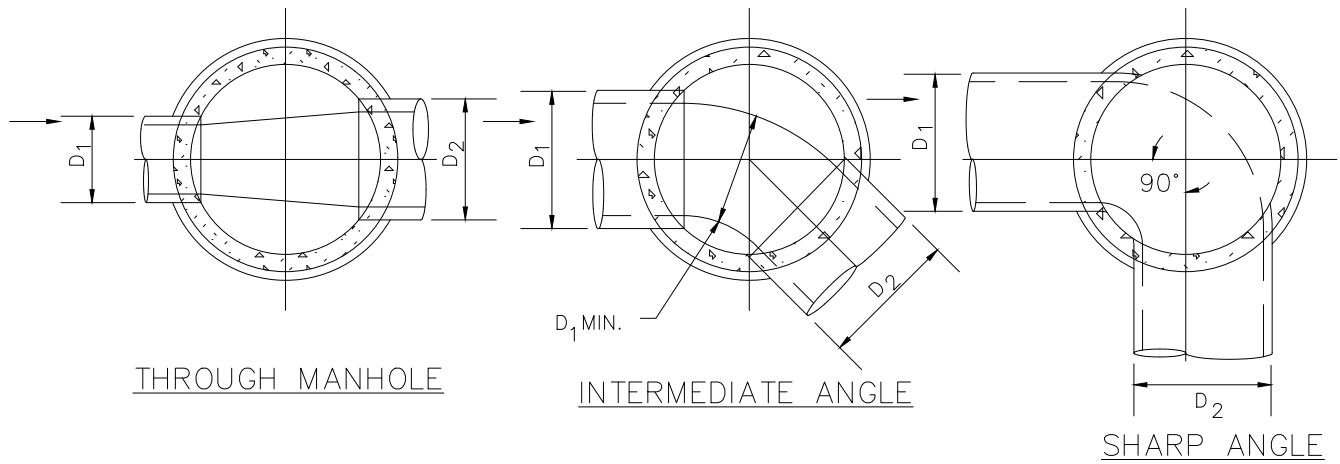

CURVED DEFLECTOR "POINT" SHALL EXTEND COMPLETELY ACROSS THE OPPOSED LATERALS AS SHOWN.

CURVED DEFLECTOR "POINTS" SHALL EXTEND ACROSS THE CENTERLINE OF THE OPPOSING PIPES AS SHOWN.

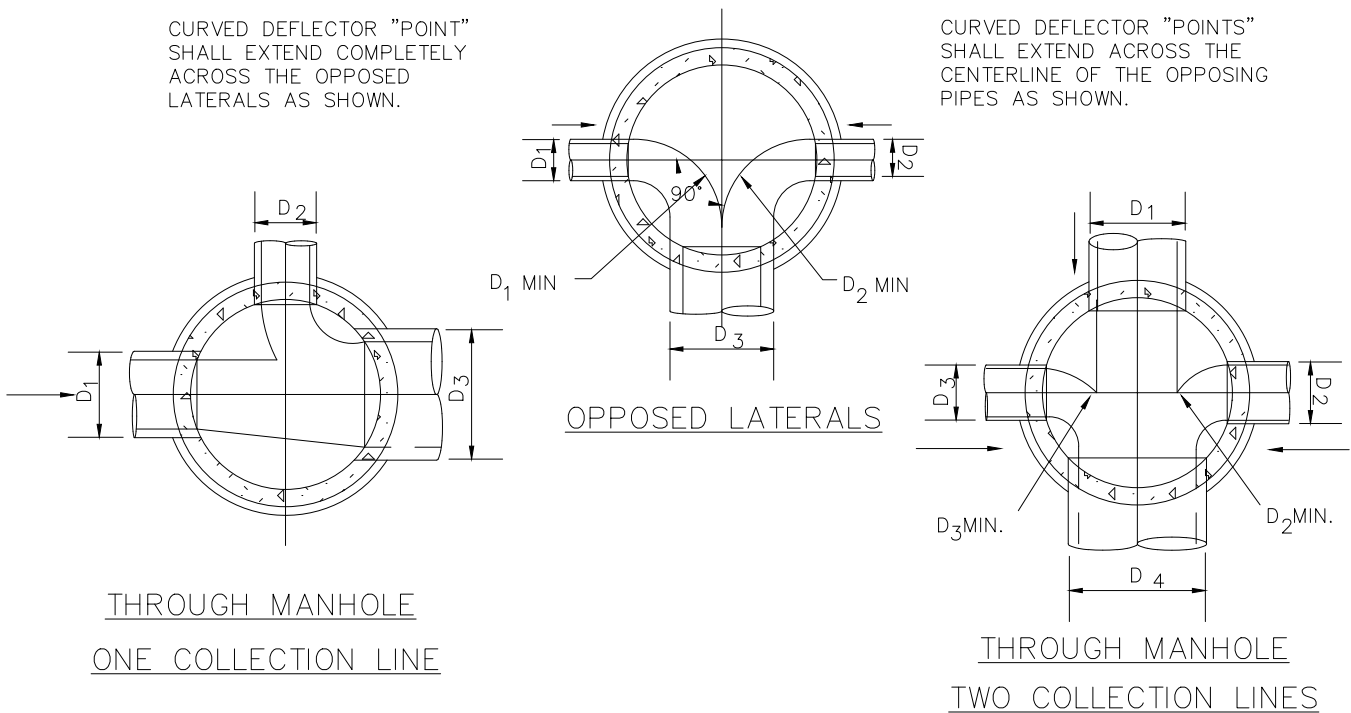

NOTES:

1. PIPE INVERT ELEVATIONS AND DROP THROUGH MANHOLES SHALL BE IN CONFORMANCE WITH THE APPROVED CONSTRUCTION PLANS. THE INTENTION IS TO PROMOTE SMOOTH, NON-TURBULENT FLOW THROUGH THE MANHOLES BY KEEPING THE LARGER LINES LOWER IN THE MANHOLE AND BRINGING THE SMALLER LINES IN SLIGHTLY HIGHER.
2. MAXIMUM INSIDE DROP THROUGH ANY MANHOLE SHALL BE 12 INCHES.
3. MINIMUM DROP THROUGH ANY MANHOLE SHALL BE 0.2 FT.
4. ALL INVERT DEFLECTORS SHALL BE CURVED IN SHAPE TO PROVIDE SMOOTH FLOW TRANSITIONS AS SHOWN ON THIS DETAIL.
5. MINIMUM ANGLE BETWEEN THE CENTERLINE OF ANY INCOMING PIPE AND THE CENTERLINE OF THE OUTGOING PIPE SHALL BE 90 DEGREES.

	34501 E. Quincy Ave., Bldg. 34 WATKINS, COLORADO 80137 Tel: (303) 292-3456 www.purecycplewater.com
<h2 style="margin: 0;">BASE AND DEFLECTOR</h2>	
Date: MAY 2018	SHEET No. 104

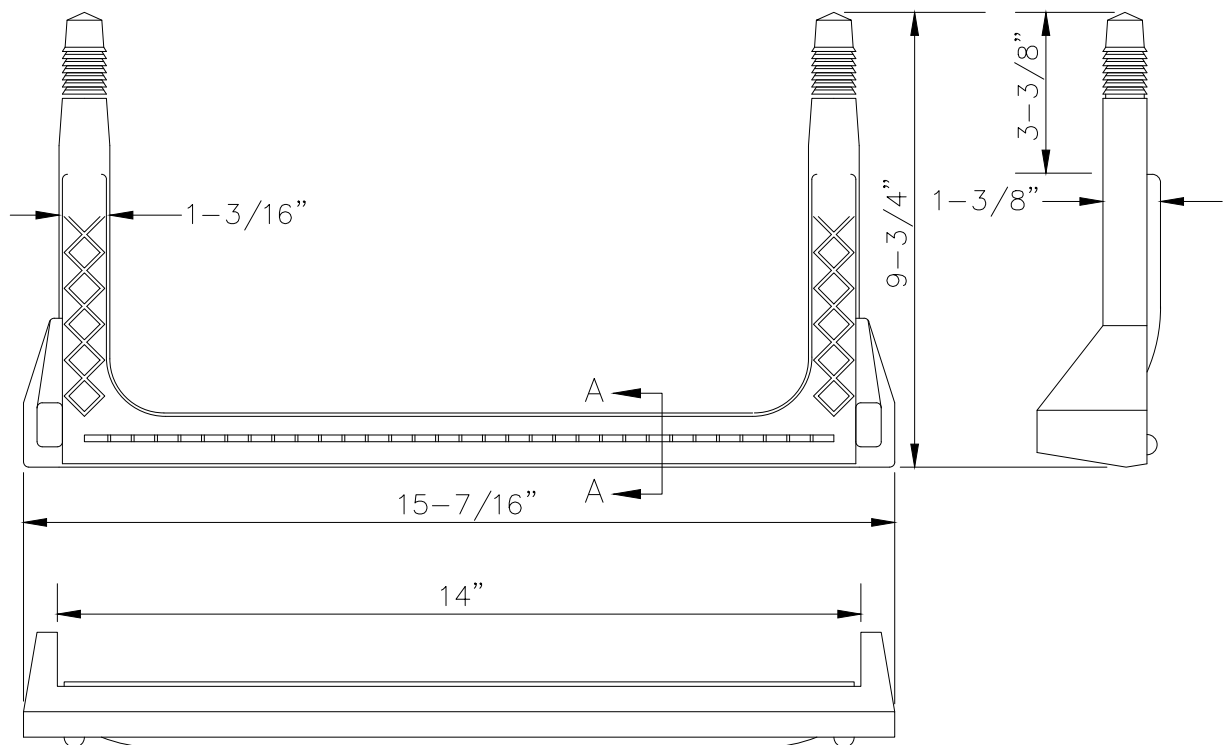

COPOLYMER POLYPROPYLENE PLASTIC

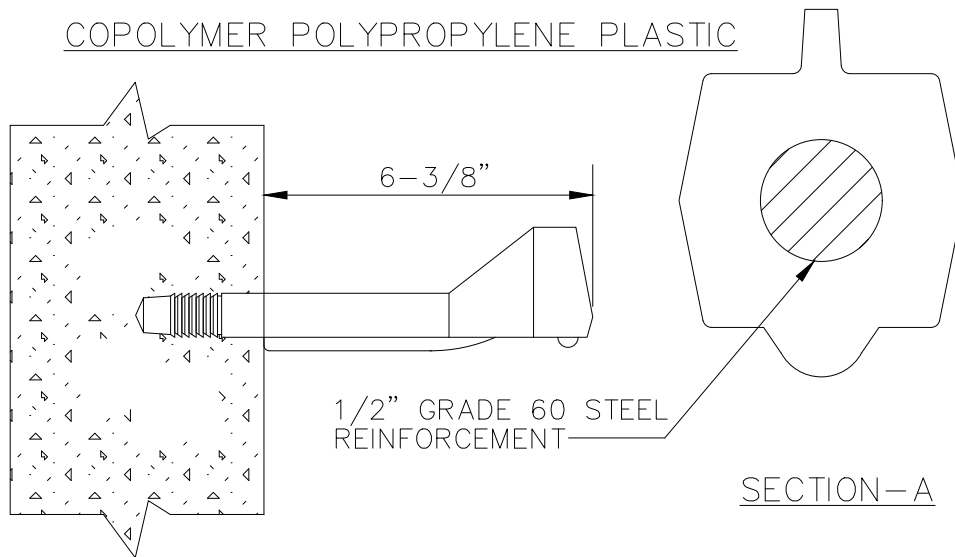

NOTE:

1. MA INDUSTRIES PS2-PF OR APPROVED EQUAL.

 34501 E. Quincy Ave., Bldg. 34
 WATKINS, COLORADO 80137
 Tel: (303) 292-3456
 www.purecyclewater.com

PLASTIC STEP

Date: MAY 2018

SHEET No. 106

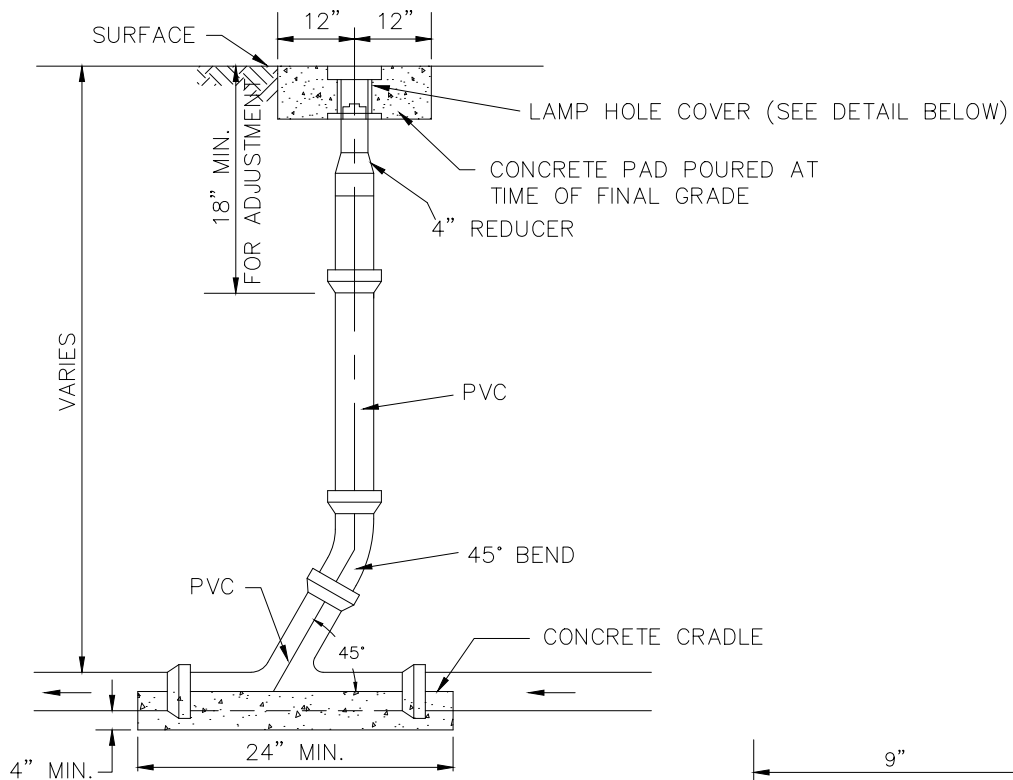

PLAN VIEW

NOTES:

1. COVER SHALL HAVE A LOCKING LID MARKED "SEWER".
2. TYLER SERIES 6855 SLIP TYPE TOP SECTION,
D & L SUPPLY SERIES M8056 OR EQUAL.
3. I.D. = 6 1/8".

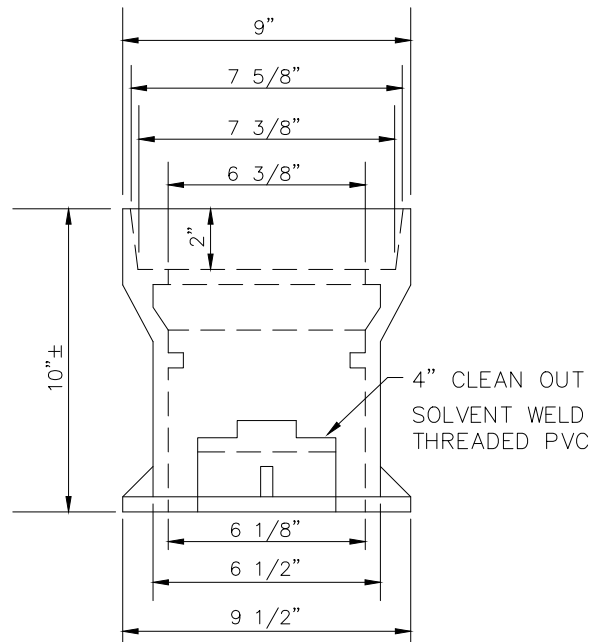

COVER DETAIL

	34501 E. Quincy Ave., Bldg. 34 WATKINS, COLORADO 80137 Tel: (303) 292-3456 www.purecyclegwater.com
	<h2>IN-LINE CLEANOUT</h2>
Date: MAY 2018	SHEET No. 107

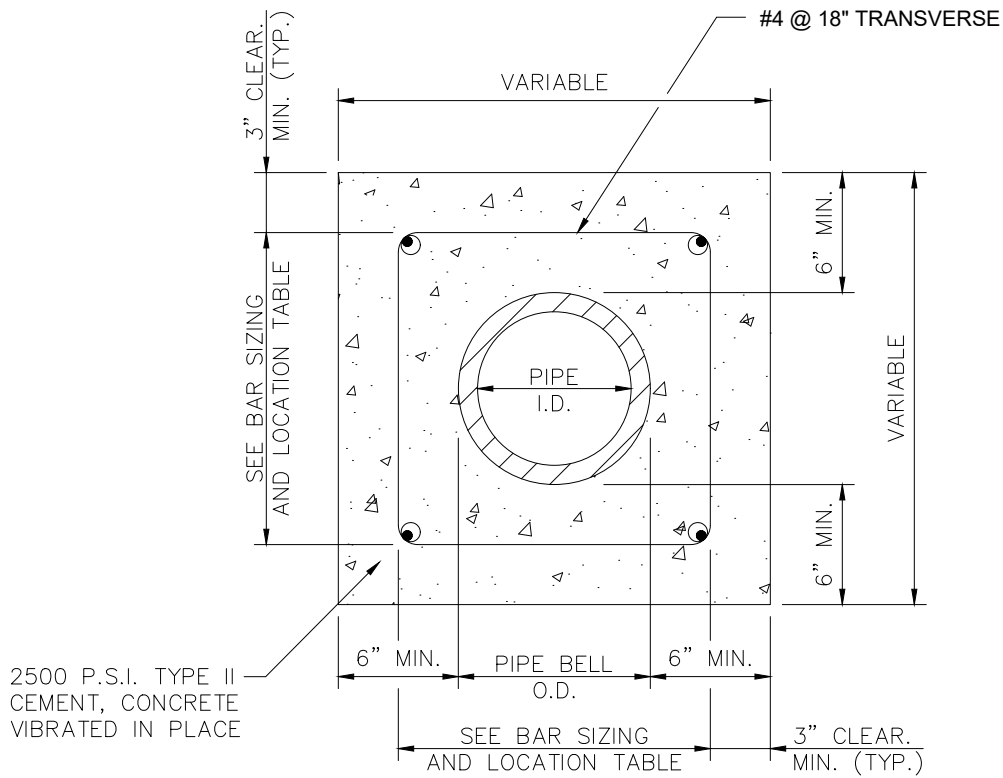

REINFORCEMENT STEEL

PIPE I.D.	LONGITUDINAL BARS – LOCATION		
4 IN.	4-NO. 4 BARS	1 EACH	CORNER
6 IN.	4-NO. 4 BARS	1 EACH	CORNER
8 IN.	4-NO. 4 BARS	1 EACH	CORNER
10 IN.	8-NO. 4 BARS	3 EACH	SIDE
12 IN.	8-NO. 4 BARS	3 EACH	SIDE
15 IN.	8-NO. 4 BARS	3 EACH	SIDE
18 IN.	8-NO. 4 BARS	3 EACH	SIDE
21 IN.	12-NO. 4 BARS	4 EACH	SIDE
24 IN.	12-NO. 4 BARS	4 EACH	SIDE
27 IN.	12-NO. 4 BARS	4 EACH	SIDE
30 IN.	12-NO. 4 BARS	4 EACH	SIDE
33 IN.	12-NO. 4 BARS	4 EACH	SIDE
36 IN.	16-NO. 4 BARS	5 EACH	SIDE

NOTE:

THE DISTRICT SHALL REVIEW THIS DETAIL FOR USE ON A CASE BY CASE BASIS. SPECIAL ENCASEMENTS MAY BE REQUIRED AT CREEK CROSSINGS AND CONDUIT CROSSINGS.



34501 E. Quincy Ave., Bldg. 34
 WATKINS, COLORADO 80137
 Tel: (303) 292-3456
 www.purecyclegwater.com

CONCRETE ENCASEMENT

Date: MAY 2018

SHEET No. 109

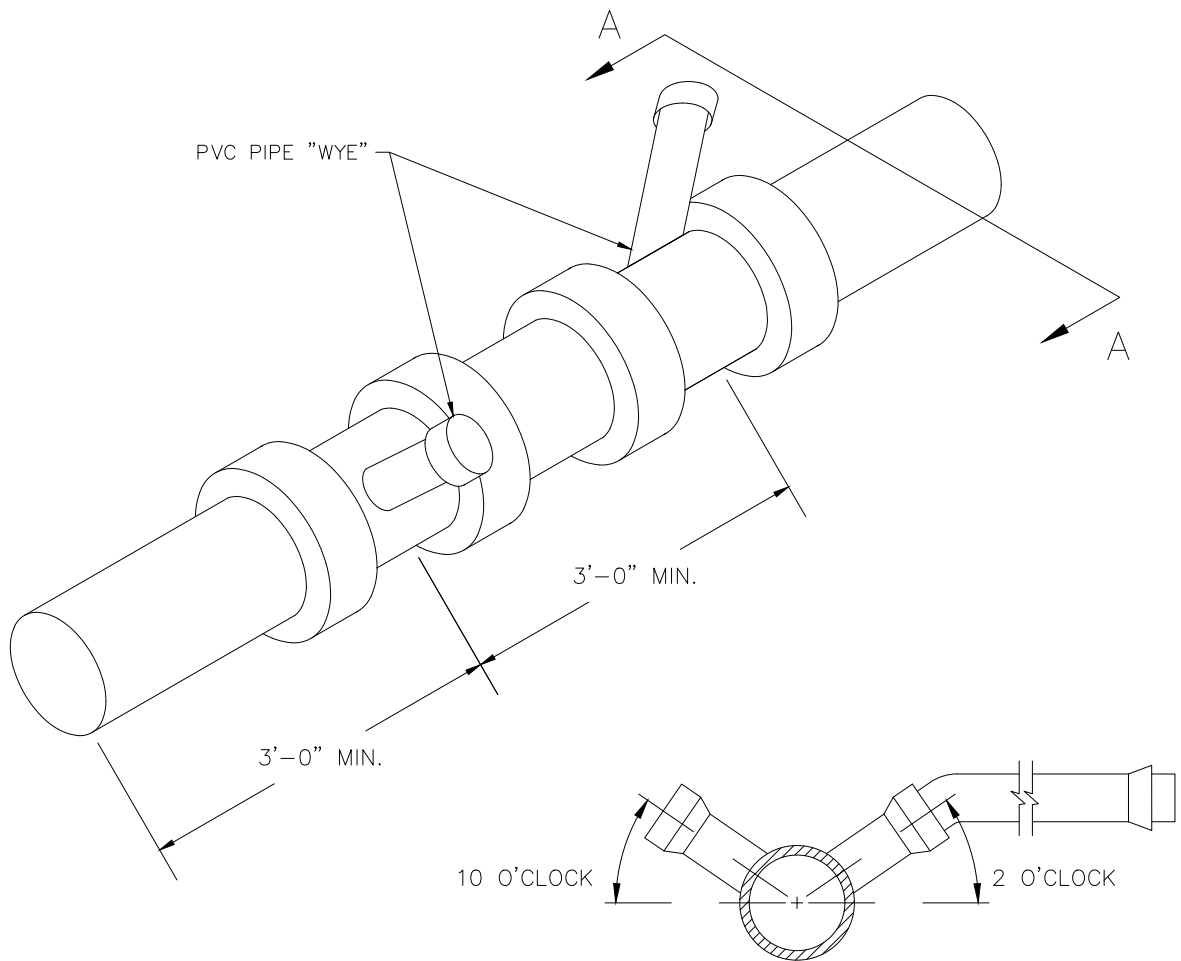

SECTION A-A
TAPS IN STAGGERED CONFIGURATION AT
10 O'CLOCK OR 2 O'CLOCK POSITION

NOTES:

1. SANITARY SEWER SERVICE TAPS SHALL BE LOCATED ON THE MAIN AT THE 2 O'CLOCK OR 10 O'CLOCK POSITION.
2. THE MINIMUM DISTANCE BETWEEN ANY TWO CONSECUTIVE FITTINGS SHALL BE 3 FEET, MEASURED BETWEEN FITTING CENTERLINES.
3. SANITARY SEWER SERVICE TAPS SHALL NOT BE MADE WITHIN 3 FEET OF A PIPE JOINT, OR 5 FEET FROM EDGE OF MANHOLE BASE.
4. A MAXIMUM OF FOUR SERVICE TAPS ARE ALLOWED PER 20 FOOT LENGTH OF PIPE.
5. ALL SANITARY SEWER TAPS SHALL USE "WYE" STYLE FITTINGS. TEES ARE NOT ALLOWED.
6. SERVICE CONNECTIONS TO MANHOLES SHALL BE PERFORMED IN ACCORDANCE WITH THE "SERVICE CONNECTION TO DEAD-END MANHOLE" CONSTRUCTION DETAIL.

 34501 E. Quincy Ave., Bldg. 34
 WATKINS, COLORADO 80137
 Tel: (303) 292-3456
www.purecyclegwater.com

SEWER SERVICE CONNECTION TO
NEW

Date: MARCH 2021

SHEET No. 118

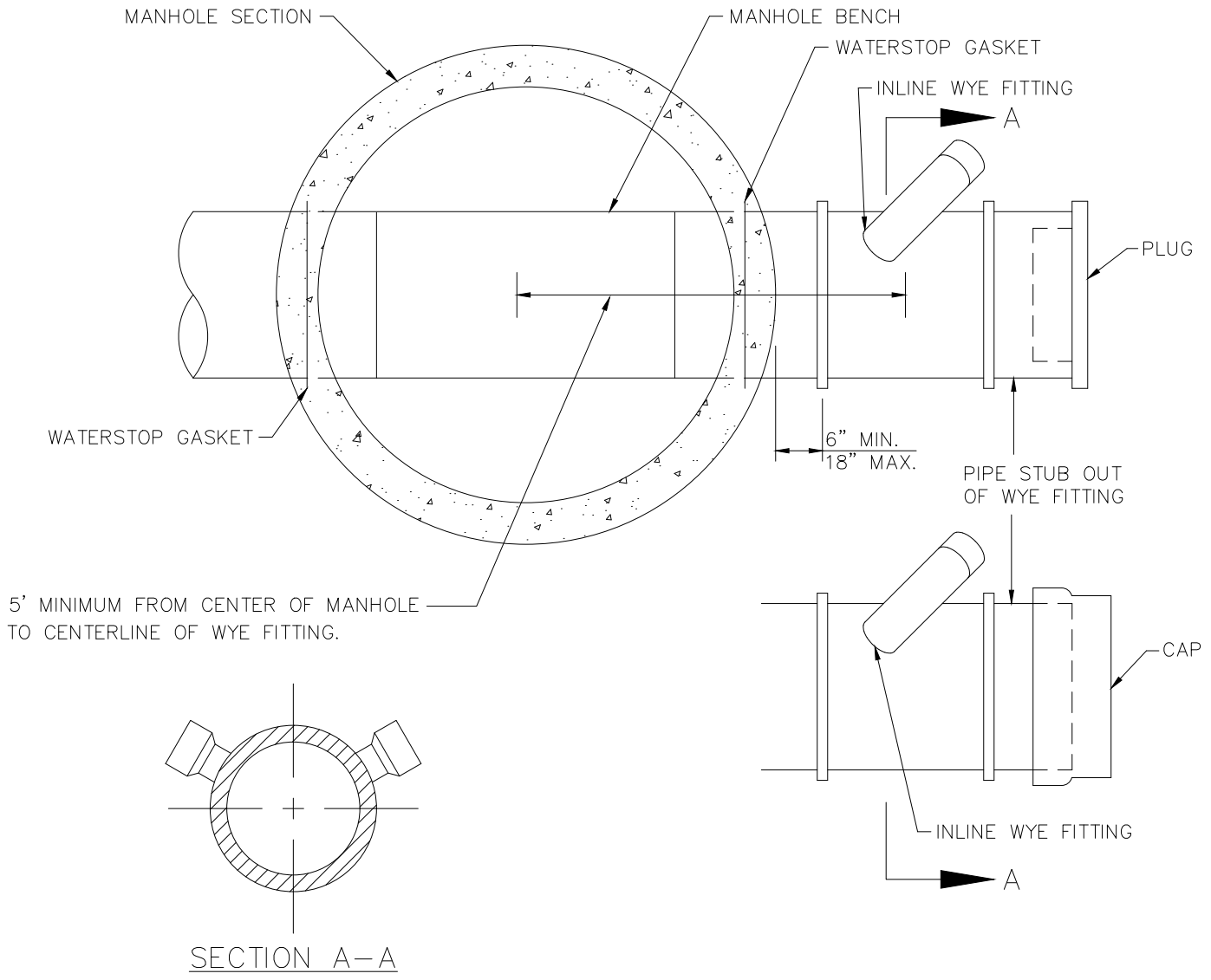

5' MINIMUM FROM CENTER OF MANHOLE TO CENTERLINE OF WYE FITTING.

SECTION A-A

NOTE:
TAPS IN STAGGERED CONFIGURATION AT 10 O'CLOCK OR 2 O'CLOCK POSITION.

NOTES:

1. USE IN CONJUNCTION WITH THE STANDARD MANHOLE DETAIL.
2. SLOPE OUT OF MANHOLE TO WYE FITTING IS TO BE AT LEAST 0.5%

	34501 E. Quincy Ave., Bldg. 34 WATKINS, COLORADO 80137 Tel: (303) 292-3456 www.purecyclewater.com
	SERVICE CONNECTION TO DEAD-END MANHOLE
Date: MAY 2018	SHEET No. 133

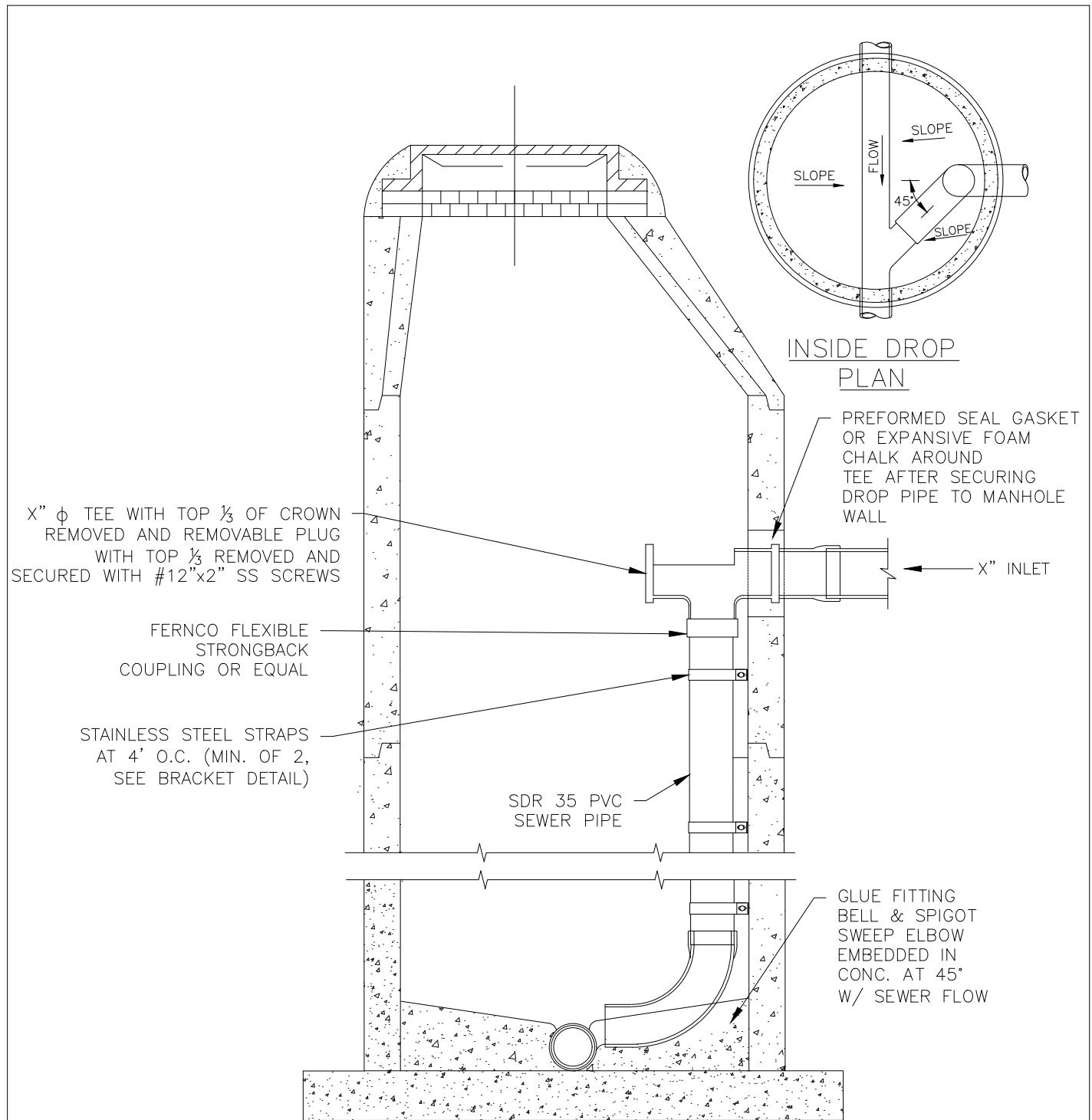

INSIDE DROP
PLAN

X" ϕ TEE WITH TOP $\frac{1}{3}$ OF CROWN
REMOVED AND REMOVABLE PLUG
WITH TOP $\frac{1}{3}$ REMOVED AND
SECURED WITH #12"x2" SS SCREWS

FERNCO FLEXIBLE
STRONGBACK
COUPLING OR EQUAL

STAINLESS STEEL STRAPS
AT 4' O.C. (MIN. OF 2,
SEE BRACKET DETAIL)

SDR 35 PVC
SEWER PIPE

PREFORMED SEAL GASKET
OR EXPANSIVE FOAM
CHALK AROUND
TEE AFTER SECURING
DROP PIPE TO MANHOLE
WALL

X" INLET

GLUE FITTING
BELL & SPIGOT
SWEEP ELBOW
EMBEDDED IN
CONC. AT 45°
W/ SEWER FLOW

INSIDE DROP – SECTION

NOTES:

1. CONTRACTOR SHALL SUBMIT SHOP DRAWINGS FOR INSIDE DROP PIPE AND FITTINGS.
2. MORTAR GROUT SHALL BE MIXED WITH TYPE II CEMENT.
3. SEE "PRECAST MANHOILE" SHEET FOR ADDITIONAL INFORMATION ON MANHOLE, STEPS, COVER, ETC.



34501 E. Quincy Ave., Bldg. 34
WATKINS, COLORADO 80137
Tel: (303) 292-3456
www.purecyclegwater.com

INSIDE DROP MANHOLE
CONNECTIONS

Date: MARCH 2021

SHEET No. 135

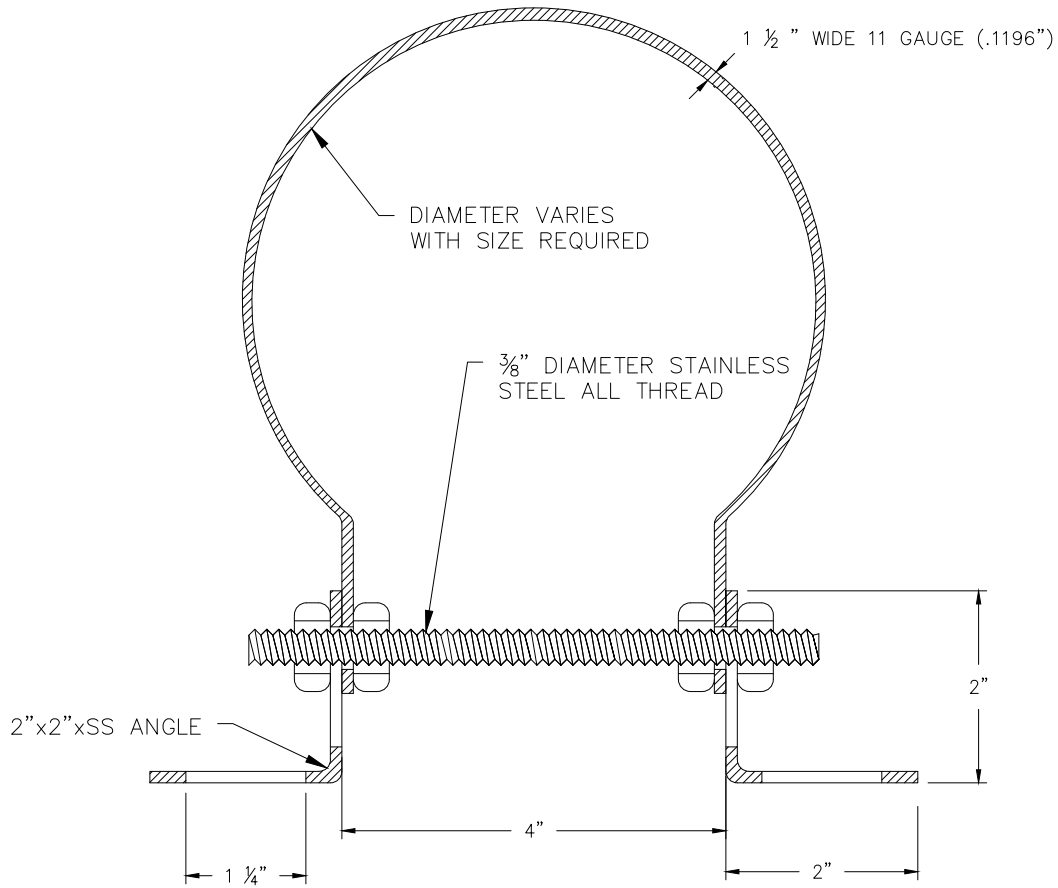

TOP VIEW

SPECIFICATIONS:

- 1) CLAMPS AND BRACKETS ARE TYPE 304 STAINLESS STEEL, 11 GAUGE (.1196").
- 2) 3/8" ϕ PINCH BOLTS AND NUTS ARE TYPE 18-8 STAINLESS STEEL.
- 3) SECURE BRACKET TO MH WALL WITH TWO 3/8x4" EXPANSION ANCHORS



34501 E. Quincy Ave., Bldg. 34
 WATKINS, COLORADO 80137
 Tel: (303) 292-3456
 www.purecyclegwater.com

DROP PIPE SUPPORT
 BRACKET

Date: MAY 2018

SHEET No. 137

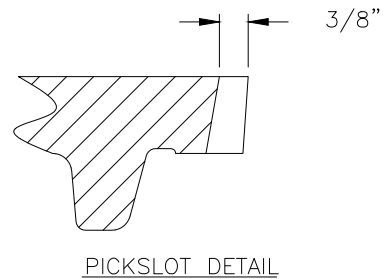
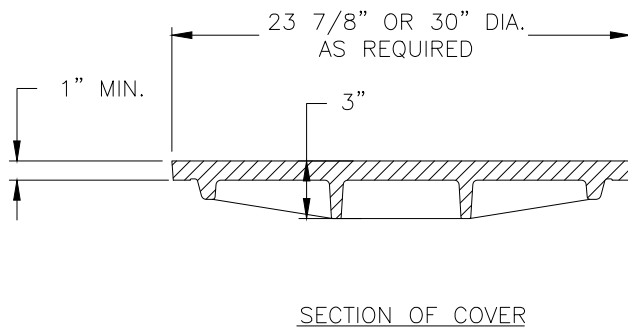
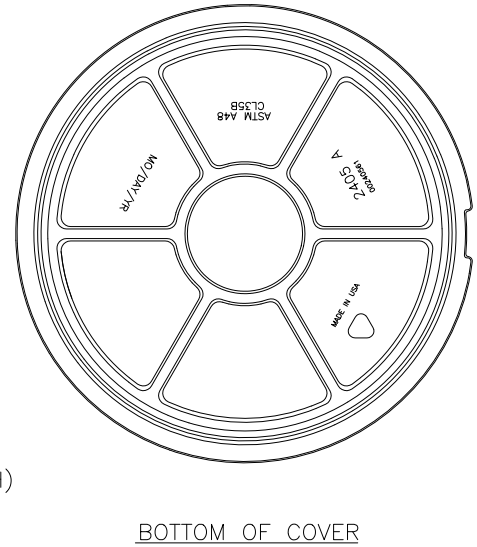
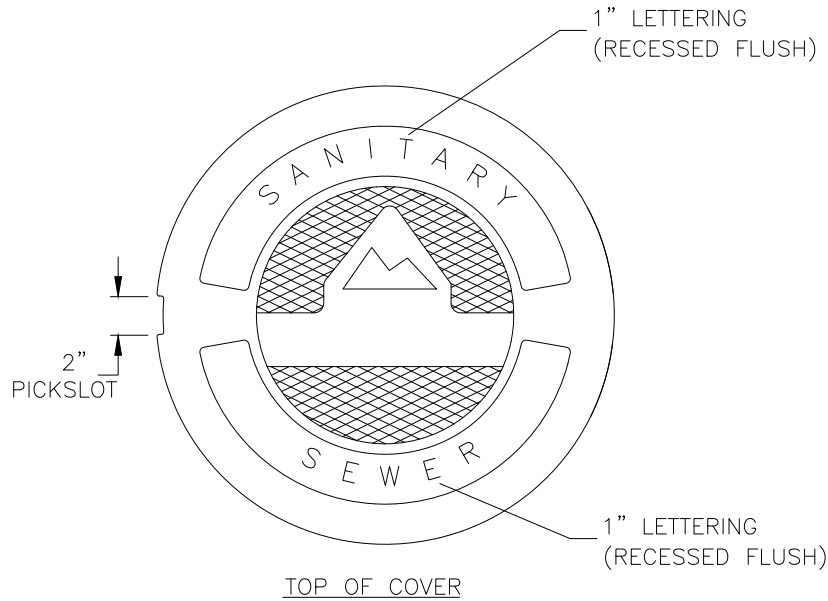

1. 23-7/8" COVERS SHALL BE USED WITH 21" AND SMALLER SEWER MAINS.
30" COVERS SHALL BE USED WITH 24" AND LARGER SEWER MAINS.
2. STANDARD (NON-HINGED) COVERS SHALL BE REQUIRED IN ALL PAVED AREAS.
3. CASTINGS SHALL BE GRAY IRON AND CONFORM TO THE REQUIREMENTS OF ASTM A48 CL35B AND HAVE AASHTO H-20 LOAD RATING.

	34501 E. Quincy Ave., Bldg. 34 WATKINS, COLORADO 80137 Tel: (303) 292-3456 www.purecyclewater.com
	STANDARD SANITARY SEWER COVER IN PAVED AREAS
Date: MAY 2018	SHEET No. 139

RING AND COVER ELEVATION SHALL COMPLY WITH THE CITY/COUNTY REQUIREMENTS.

12" PVC SDR-35

24" MH RING AND COVER (SEE DETAIL)

8" PVC DR-25 C900

CEMENT GROUT OR MORTAR

CONCRETE GRADE RINGS (12" VERTICAL ADJUSTMENT MAX.)

ECCENTRIC CONE (OR FLAT COVER WHERE DEPTH LESS THAN 6 FEET)

20" MAX.

VARIABLE PRECAST CONCRETE SECTIONS

STEPS AT 16" O.C. POSITION OVER LARGEST BENCH IN VERTICAL LINE

PRECAST

MANHOLE I.D.

SET EACH RING IN FULL BED OF BITUMINOUS MASTIC (RAMNECK)

GROUT ALL INSIDE JOINTS AND LIFT HOLES.

SEAL OUTSIDE JOINT WITH MORTAR

WATERSTOP GASKET

MIN. 1/3 OF INLET PIPE SIZE

5" MIN.

WATERSTOP GASKET

20" MIN.

SEE PLANS FOR PIPE SIZE

MANHOLE I.D.+16"

SEE PLANS FOR PIPE SIZE

#4 @ 12" O.C. E.W. 3" CLEAR

POURED IN PLACE CONCRETE BASE

FLOW DIRECTION

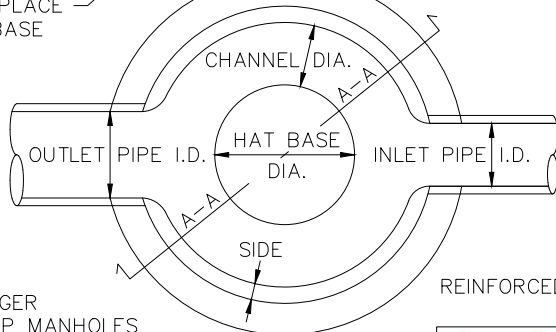

REINFORCED CONCRETE

INLET PIPE I.D.	OUTLET PIPE I.D.
8"	12"

SIDE	CHANNEL DIA.	HAT BASE DIA.
6"	8"	20"

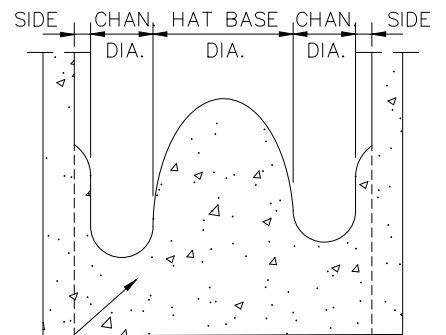

A-A SECTION VIEW

NOTE: USE ONE-SIZE LARGER MANHOLE FOR INSIDE-DROP MANHOLES

PIPE I.D.	MANHOLE I.D.	RING & COVER
15" & SMALLER	4'-0"▲	24"
18" TO 21"	5'-0"	30"
24" TO 30"	6'-0"	30"

▲ WHENEVER MORE THAN A TWO WAY MANHOLE OF MAX. PIPE I.D. IS REQUIRED, THE MANHOLE SHOULD BE INCREASED TO LARGER DIA., EG. 18"x18"x18", REQUIRES 5'-0" I.D.

NOTES:

1. MANHOLE BARREL MIN. DIA. SHALL CONFORM TO TABLE BELOW.
2. SHAPING FOR SMOOTH MANHOLE INVERTS MUST BE DONE BY FORMING OR SHAPING BASE CONCRETE.
3. PLASTIC MANHOLE STEPS.
4. PRECAST CONCRETE SECTIONS SHALL CONFORM TO ASTM C-478, & AASHTO H-20 LIVE LOADS.
5. BLOCK-OUTS WHEN APPROVED SHALL EXTEND A MAX OF 6" PAST MANHOLE O.D. AND BE SATISFACTORILY PLUGGED AND SEALED.
6. ALL MORTAR GROUT SHALL BE MIXED WITH TYPE II CEMENT.
7. BENCH MUST HAVE A BRUSHED, NON-SKID SURFACE.
8. PRE-CAST CONCRETE BASES SHALL NOT BE USED WITHOUT PRIOR APPROVAL OF THE DISTRICT.
9. CHANNEL DIAMETER SHALL BE EQUAL TO INLET PIPE I.D. FOR INLET PIPE I.D. EQUAL OR LESS THAN 15".
10. HAT BASE DIA. SHALL NOT BE LESS THAN 18".
11. THE SIDE DIMENSION SHALL NOT BE LESS THAN 4". IF IS LESS THAN 4" ADJUST THE HAT BASE DIA. AND GO WITHOUT THE SIDES.
12. FOR INLET PIPE I.D. OF 15" AND LARGER USE TABLE BELOW.

 34501 E. Quincy Ave., Bldg. 34
 WATKINS, COLORADO 80137
 Tel: (303) 292-3456
 www.purecyclewater.com

MEXICAN HAT (SOMBRERO) MANHOLE
SKY RANCH SPECIFIC

Date: MARCH 2021 | SHEET No. 146